



PROSWING

S/M VERSION

AUTOMATISM FOR SWINGING DOORS
OPERATING INSTRUCTIONS

ENGLISH

Thank you for choosing this product. For best automatism performance, Sesamo recommends you carefully read and follow the installation and use instructions found in this manual. Installation of this automatism must only be performed by the professionally qualified personnel for whom this manual is addressed. Any errors during installation may be harmful to people or things. Packaging material (wood, plastic, cardboard, etc.) should not be scattered in the environment or left within the reach of children as potential sources of danger. Every installation phase must be performed in accordance with the regulations in force and following Good Technique standards. Before beginning installation make sure that the product is integral and has not been damaged during transportation or by poor storage conditions. Before installing the product make sure that each architectural and structural element of the entrance (girder fastening surfaces, casings, guide, etc.) is appropriate and sufficiently robust to be automated. Conduct a careful risk analysis and make suitable modifications to eliminate conveyance, crushing, cutting and hazardous areas in general. Do not install the product in environments where gas, steam or inflammable fumes are present. The manufacturer is not liable for any neglect of "good technique" or specific regulations in the construction of the casing to be motorized and any collapse of the same. All automatic entrance safety and protection devices (photocells, active sensors, etc.) must be installed in accordance with the regulations and directives in force, with the completed risk analysis, system type, use, traffic, forces and inertia in play. Pay careful attention to area where the following may occur: crushing, cutting, conveyance and any other type of hazard in general applying, if necessary suitable indications. Indicate the motorized door identification information on every installation. Make sure that the upstream electrical system is correctly dimensioned and has all the opportune protections (circuit breakers and fuses). Only use original spare parts in maintenance and repairs. Do not tamper or alter devices in the automatism and all the safety devices in the control panel for any reason. The manufacturer is not liable if parts within the automatism are altered or tampered with or if safety devices other than those indicated by the manufacturer are used in the system. The automatism installer must provide the automatic entrance manager with the use manual and all the information required for correct use in automatic and manual modes (even for electronic locking) and in the event of emergency. Pay careful attention to the messages in this manual that are marked with the hazard symbol. They can either be warnings aimed at avoided potential equipment damage or specific signals of potential hazard to the installer and others. This device was designed to automate pedestrian swinging doors. Any other use is considered contrary to the use foreseen by the manufacturer who therefore shall not be held liable.

MACHINE DIRECTIVE

The installer who motorised a door becomes the automatic door machine manufacturer according to directive 2006/42/CE and must:

- Arrange the Technical Booklet with the documents indicated in attachment VII of the Machine Directive and keep them for at least 10 years.
- Draft the CE declaration of conformity according to attachment II-A of the machine directive and provide the user with a copy.
- Apply the CE markings on the motorized door according to point 1.7.3 of attachment I of the machine directive.
- In particular, but not exclusively, if for the purpose of the standard EN 16005 it is necessary to install monitored sensors, the wiring has to carry out as described in this manual (see pages 13/14/15/19) and the correct sensors operation has to be checked following instruction manual of the sensors themselves.

For more information and for assist installers in applying the specifications of the directives and of European standards concerning the safe use of motorized gates/doors consult the guidelines available on internet at the address www.sesamo.eu

DECLARATION OF INCORPORATION

(Directive 2006/42/CE, Annex II, part B)

Manufacturer: SESAMO S.R.L.

Address: Str. Gabannone 8/10 - 15030 Terruggia – AL -ITALY

Declares that the product: PROSWING

- is made to be incorporated in a machine to construct a machine considered by Directive 2006/42/CE
 - conforms with the essential safety requirements indicated in appendix I of the directive with the exception of the following points: 1.2.4.3, 1.2.4.4, 1.3.4, 1.3.5, 1.3.7, 1.3.8.2, 1.4, 1.5.3, 1.5.7, 1.5.14, 1.5.15, 1.5.16
 - complies with the conditions of the following other CE Directives: 2014/30/UE Electromagnetic Compatibility, 2014/35/UE Low Voltage
- and that
- the following (parts/clauses of) agreed regulations have been applied:
EN 60335-1 EN 61000-6-2 EN 50366 EN 61000 -6-3 EN16005
- and also declares that:
- the relevant technical documentation has been completed in accordance with part B of appendix VII; this documentation, or parts of it, will be delivered electronically or by traditional post upon justified request from the competent national authorities
 - the relative technical documentation will be compiled by: SESAMO SRL, Strada Gabannone, 8/10 - 15030 Terruggia (AL) - Italy
 - it is not permitted to use the product until the machine in which it will be incorporated or will become a component of has been identified and has received the declaration of conformity with the conditions of Directive 2006/42/CE and the national legislation that transposes it, in other words, until the machinery referred to in this declaration forms a single unit with the machine.

SESAMO S.R.L.
May 2016

Aldo Amerio
(Director)



TECHNICAL SPECIFICATIONS

DIMENSIONS	see Fig.1
POWER SUPPLY	230V ±10% AC 50/60Hz
NOMINAL POWER	85W
NOMINAL MOTOR TORQUE	45Nm
EXTERNAL DEVICE POWER	15VDC - 12W MAX
POWER BATTERY KIT ⁽¹⁾	24V - 1,3Ah
OPENING TIME	3s ÷ 6s (70°/s ÷ 20°/s)
CLOSING TIME	4s ÷ 15s (40°/s ÷ 10°/s)
CLOSING FORCE (ACCORDING EN 1154) ⁽²⁾	EN4 ÷ EN6
MAX OPENING ANGLE	110°
WING DIMENSION	700 ÷ 1400 mm
MAX. WING PAYLOAD	see Fig.2
WORKING TEMPERATURE	from -10°C to +50°C
ANTI-CRUSHING	Automatic traction restriction in presence of obstacles
WEIGHT	11 kg approx
SERVICE	Intensive
IP	IP40

⁽¹⁾: Optional only for PROSWING M

⁽²⁾: Only PROSWING S

LOW ENERGY



PROSWING can be set in the order to meet requirements of Low-Energy application according EN16005.

- reduced dynamic force;
- low speed;
- reduced dynamic/static force.

It is installer's responsibility to verify the compliance of the installation Low-Energy compared with current standards. The protection of the closing edge must be assessed individually.

WARNINGS FOR THE INSTALLER (AND GENERAL SAFETY)

- 1)  It is important for the safety of the people installing the automatism according to the regulations. A wrong installation or use of the product might lead to serious damages to people.
- 2) Read carefully the operating instructions before installing the product.
- 3) Store the operating instructions for future reference.
- 4) This automatism has been designed and built exclusively for the use specified in this documentation. Any different use not stated herein could affect the integrity of the product and/or represent danger situation.

- 5)SESAMO declines any responsibility from misuse or different use from which it was intended.
- 6)Do not install the product in explosive environment: the presence of flammable gases or fumes is a serious safety hazard.
- 7)SESAMO is not responsible for the failure to comply with the Good Technical construction procedure of the door to be automated, as well as deformations that may occur to the door when using the same.
- 8)Before making any service to the product, switch off power supply.
- 9)Install a bi-polar switch to cut off power supply.
- 10)Verify functionality of ground wiring.
- 11)Safety devices (norm EN 12978) protect possible dangerous areas from mechanical risks during movement, as. anti-crashing, conveying, shearing.
- 12)For maintenance use only genuine SESAMO spare parts.
- 13)Do not modify components that belongs to the whole automatism.
- 14)The installer must supply end user all the information in case of manual operating in emergency.
- 15)End user shall refrain from any attempt to repair or direct intervention and ask only to qualified personnel.
- 16)  Installation must be done only from a qualified personnel and in full compliance with regulations.
- 17) Everything not including in this operating instruction manual is not allowed.
- 18)  This operating instructions manual is only intended for qualified personnel.

RECYCLING AND DISPOSAL

This product is built with different materials. The major parts (aluminum, plastic, iron, wires) are solid urban waste. They can be recycled through collection and disposal in authorized centers. Other components (control boards, etc.) may contain pollutants. They need to be removed and hand over to companies authorized to recover and dispose them. The packaging (paperboard, plastics etc.) are solid urban waste and they can be disposed of without any problem, simply performing waste collection for recycling. Before proceeding it is always recommended to verify local specific norm for disposal.

PLEASE RECYCLE!

INTENDED USE

The device must be used to automate pedestrian swinging door only.

This device is an electro mechanical system that allows to open and close a swinging door using a transmission arm.

Door closing:

- by spring/motor or only spring in case of power failure (PROSWING S)
- by motor (PROSWING M)

Programmable electronic control board allows correct functioning depending on the type of installation.

limit of use



ATTENTION: Do not exceed door weight and width as shown in the diagram in “technical specification” paragraph. Fig.2. At each transmission arm also corresponds a different value of the maximum depth of the jamb that must not be over taken in order to perform a proper installation of the system. This device is intended only for swinging pedestrian door, dry and inside use. SESAMO shall not be held liable for any other use contrary to the use foreseen.

TYPES OF ARMS

- PULL ARM :the pulling arm can be fitted: PULL (it is used when the automatism is installed on the same side of the door opening).
- STANDARD PUSH ARM: the pushing arm can be fitted : PUSH (it is used when the automatism is installed on the opposite side of the door opening).
- LONG PUSH ARM: the long push arm can be fitted: PUSH (it is used when the automatism is installed in the opposite side of the door opening).
-  **ATTENTION:** For a proper positioning refers to paragraphs “Arms Installation”.

PRELIMINARY CHECKS

Before installing the automatism please check:

- verify the installation does not create dangerous situations;
- prearrange proper pipes and conduits for the wires, granting the protection of the same against mechanical damages;
- the surface where fixing the automatism has to be resistant. Use screws, bolts, etc. adequate to the type of surface;
- the structure of the door has to be strong to hold the weight of the automatism as well the hinges, also check to not have friction between fixed and mobile parts;
- use proper equipment and tools to install in security and in accordance with the regulations.

AUTOMATISM FIXING

Refer to Fig.4 (Proswing M) and Fig.5 (Proswing S), to fix automatism proceed as follows:

- remove cover (B);
- disconnect all wiring (encoder, switches, transformer, motor) on control board (C);
- unscrew the 2 screws and remove control board with its support (C) (screws remain between control board and support);
- unscrew the 2 screws (G) and remove transform;
- unscrew the 4 screws (D) and remove gear motor;
- If present, unscrew the screw that close the batteries (H) and remove them (only Proswing M)
- unscrew the screws and remove end caps (E) and (F);
- fix aluminum base (A) to the structure following instructions of the following paragraphs, depending on arm type;
- reassemble all components except end caps and aluminum cover.

To make easier reassembling gear motor, partially screw the screws, then lean gear motor on to them. Insert screws. Tight all screws paying attention that gear motor axis is perpendicular to the door top edge.

ALUMINIUM BASE HOLES POSITIONING

 Drill holes according to the type of screws chosen and fix the base only after verifying the “Positioning dimensions” listed in the paragraph concerning the type of arm selected. With double automatism prearrange the connection (wiring) between the two single automatism.

PULL ARM INSTALLATION

Pull arm has to be used when automatism is installed on the same side of door opening.

 **ATTENTION:** For a correct positioning always refer to the hinge axis and gear motor axis, as shown in Fig.6 (wing opening left) e Fig.7 (wing opening right).

 **ATTENTION:** final tightening of the screws must be performed only after checking that vertical positioning of the automatism allow a good parallelism between hinge axis and gear motor axis. Therefore, after fixing the pulling arm and its guide, the coupling bolt of the arm with the cylindrical skid have not to create force in opening/closing cycle. A positioning error of the automatism might create bending between the bolt of the pulling arm and the cylindrical skid more than the allowed tolerance, damaging parts of the automatism.

 Depending on the depth of jamb dimension, it might decreases the maximum opening angle.

INSTALLATION SLIDING GUIDE OF THE PULLING ARM (PROSWING S)

- Remove the cover (Fig.10 Part.A) of the guide (Fig.10 part.B)
- Fix guide profile horizontally (Fig.10 part. B) to the door following dimensions shown in Fig.6 e Fig.7.
- Unthread profile and drill 4 holes on the “V” mark on guide profile and fixed the guide to the wing through adequate screws (Fig.10 part.B).
- Insert skid (Fig.10 part.C) inside the guide (Fig.10 part.B)
- Tighten screw (Fig. 13 part. A) to tension the spring up to the end of the plate (Fig. 13 part. B) matches the line indicating field EN4 (L=0).
- With door in closed position find arm position (Fig.12. part A) in such a way that end of arm (Fig.10 part. F) meets the skid (Fig.10 part.C).
- Remove arm, remove arm extension (Fig.12. part A) and rotate it of 1 or 2 teeth in the direction of door closing (Fig. 15) and insert it again on the shaft.
- Insert washer (Fig.12 part.B) and tight screw (Fig.12 part.C) into arm extension.
- Loosen screw (Fig.13 part.A)
- Insert arm (Fig.12 part.D) in the arm extension slot, and tight screws (Fig.12 part.E).

 **ATTENTION THE MAX. TORQUE TO BE USED TO TIGHTEN SCREW “E” FIG.12 IS 10.5 N/m**

- Slightly open the door, rotate arm until reaching the skid (fig 10 part. C).
- Screw skid shaft (Fig 10 part.C) into the arm (Fig 10 part.F).

- Insert guide cover profile (Fig.10 part. A)
- Insert right end cap (Fig.10 part.E) and the left end cap (Fig.10 part.D) onto the guide with their screws.
- Continue with the spring adjustment [see paragraph “Spring adjustment”].

INSTALLATION SLIDING GUIDE OF THE PULLING ARM (PROSWING M)

- Remove the cover (Fig.10 Part.A) of the guide (Fig.10 part.B)
- Fix guide profile (Fig.10 part.B) horizontally to the door following dimensions shown in Fig.6 e Fig.7.
- drill 4 holes on the “V” mark on guide profile and fixed the guide to the wing through adequate screws (Fig.10 part.B).
- Insert skid (Fig.10 part.C) inside the guide (Fig.10 part.B).
- With door in closed position find arm position (Fig.12. part A) in such a way that end of arm (Fig.10 part. F) meets the skid (Fig.10 part.C).
- Insert washer (Fig.12 part.B) and tight screw (Fig.12 part.C) into arm extension.
- Insert arm (Fig.12 part.D) in the arm extension slot, and tight screws (Fig.12 part.E).
- Slightly open the door, rotate arm until reaching the skid (fig 10 part. C).
- Screw skid shaft (Fig 10 part.C) into the arm (Fig 10 part.F).
- Insert guide cover profile (Fig.10 part. A).
- Insert right end cap (Fig.10 part.E) and the left end cap (Fig.10 part.D) onto the guide with their screws.

Verify the dimension about 17 mm (sliding guide / arm).



ATTENTION: For rigid pull arm both right/left opening set switch as shown in Fig. 17.

PUSH ARM INSTALLATION

Push arm is used when automatism is installed on the opposite side of door opening.



ATTENTION: For a correct positioning always refer to the hinge axis and gear motor axis, as shown Fig.8 (left opening) e 9 (right opening).



ATTENTION: final tightening of the screws must be performed only after checking arm can easily rotate under door jamb.



ATTENTION: increasing the passage depth, the maximum opening angle decreases

FIX PUSH ARM TO THE DOOR (PROSWING S)

- Insert washer (Fig.12 part.B) and screw (Fig.12 part.C) into arm extension (Fig.12 part.A).
- Insert arm (Fig.12 part.D) in the arm extension slot, as show in Fig. 12 and tighten screws (Fig.12 part.E).
- Unscrew screws M8 x 16 (Fig.11 part.B).
- Fix door bracket to the door following dimension shown in Fig. 8 e 9.
- Fix the arm extension (Fig.11 part.A) of the pushing arm onto the above profile of the wing through adequate screws.

 **ATTENTION:** fix door bracket considering door material in case using a reinforcement.

- Tighten screw (Fig. 13 part. A) to tension the spring up to the end of the plate (Fig.13 part. B) matches the line indicating field EN4 (quote L=0).
- Insert arm extension (Fig.12 part.A) into gear motor shaft in such a way that arm is perpendicular to the door (Fig.14).
- Tight screw (Fig.12 part.C) until arm extension is well fixed to gear motor shaft.
- Fix screws M8 x 16 (Fig.11 part.B) without tighten.
- Keeping door closed, rotate arm in order to slightly compress spring. (Fig. 14)
- Tighten screws M8 x 16 (Fig. 11 Part,B).
- Continue with spring adjustment (see paragraph “Spring adjustment”).
- **ATTENTION:** For articulated push arm, both right/left opening, set switch as shown in Fig. 17.

FIX PUSH ARM TO THE DOOR (PROSWING M)

- Insert washer (Fig.12 part.B) and screw (Fig.12 part.C) into arm extension (Fig.12 part.A).
- Insert arm (Fig.12 part.D) in the arm extension slot, as show in Fig. 12 and tighten screws (Fig.12 part.E).

 **ATTENTION THE MAX. TORQUE TO BE USED TO TIGHTEN SCREW “E” FIG.12 IS 10.5 N/m**

- Unscrew screws M8 x 16 (Fig.11 part.B) to release the arm part to be fixed onto the wing .
- Fix door bracket to the door following dimension shown in Fig. 8 e 9.
- Fix the arm extension (Fig.11 part.A) of the pushing arm onto the above profile of the wing through adequate screws.

 **ATTENZIONE:** fix the arm extension of the arm tightly, if needed use a reinforcement onto the wing.

- Insert arm extension (Fig.12 part.A) into gear motor shaft.
- Screw the screw (Fig.12 part.C) to fix the arm bracket to the shaft of the automatism .
- Keeping the door closed, rotate the part of the arm on which the arm bracket is fixed so that the two arm parts form an isosceles triangle with respect to the wall fixing point.
- Keeping door closed, rotate arm as show and tight screws M8 x 16 (Fig. 11 Part. B).

SPRING ADJUSTMENT (ONLY FOR PROSWING S)

The spring has to be charged according to the width of the door keeping in consideration the norm EN 1154 in the range from EN 4 to EN 6. Range of adjustment can be obtained from diagram (Fig. 18), according to the width and weight of the door, both for pull or push arm. During spring adjustment, wind force, over-pressure and other environmental condition that might open the door, must be considered.

Adjust force of the spring tightening the screw (Fig. 29, Part.A) in order to tension the spring up to the end of the plate (Fig.29 part. B) would be in the correspondent range of the type of installation (range EN identified).



ATTENTION: Keep in consideration the spring is a component that, when at maximum compression, accumulates very high energy, it is necessary that both the spring both the related components would be only replaced by using ORIGINAL parts. It is also recommended to program service using qualified technicians. For maintenance please have a look on the manual.

BREAKE ADJUSTEMENT WITHOUT POWER (ONLY FOR PROSWING S)

Set breaking level on terminal board (Fig. 30) to suit closing speed without power supply to door width/weight, ref. to Fig.16. Verify functionality opening door by hand and checking closing cycle with spring, without power.

PRELIMINARY CHECKING

Before electrical wiring, check as follows:

- Remove carefully dust or any other residual of the installation
- Verify automatism being well fixed
- Verify all screws well tighten
- Verify all wiring well fixed and not near moving parts
- Verify arm well fixed to door.



ATTENTION (ONLY FOR PROSWING S): ensure that the spring protection bracket is fixed (Fig.13, part. C) and that the label with the seal hasn't been removed. (Fig.13, part. D).

WIRING POWER SUPPLY



ATTENTION: Wiring the connectors of the control panel or external peripheral connections must be in absence of power supply in order to avoid irreversible damages of the electronic device.



ATTENTION: before performing the following operation make sure the power supply is OFF. Before starting the automatism, check and perform as paragraph "Start up".

- Bring the cable inside the automatism paying attention not to damage it against metallic edges.
- Open the cover (Fig.19 Part.A)
- Connect the power supply and the ground cable on the terminal (Fig.19 Part.B)
- Close the cover (Fig.19 Part.A)
- **ATTENTION:** Never invert power supply cable and ground cable. Power supply must be isolatable from the general panel with a bi-polar switch with minimum contact opening equal to 3 mm (not supplied).

CONTROL BOARD PROSWING

Fig.20 (PROSWING S) e Fig.21 (PROSWING M) show the important components of electronic control board:

- A. Expansion connector for additional board (Optional)
- B. Display and buttons
- C. Dip switches
- D. PC connector
- E. Transformer connector
- F. Batteries connector
- G. Switch ON-OFF connector
- H. Logics switch connector
- I. Auxiliary exit connexion
- J. Logics connectors
- K. Sensors / accsories power supply
- L. Selector connector
- M. Electronic lock connector
- N. Encoder connector
- O. Gear motor connector
- P. Brake level selection connector
- Q. Arm type selection

WIRING

Connect the following terminal boards (Ref.Fig.20 and 21):

- logic switch [H];
- ON-OFF switch [G];
- transformer [E];
- motor [O];
- encoder [N].

ARM TYPE SELECTION (PROSWING S)

Rigid pull arm (both right/left opening) → Set switch as shown in Fig. 17

Articulated push arm (both right/left opening) → Set switch as shown in Fig. 17

EXTERNAL PERIPHERALS CONNECTORS/INPUT

SIGNAL	DEFAULT *	DESCRIPTION	FUNCTION
KEY	NC	Lock contact. Lock devices can be connected such as electronic key, key selector, proximity reader, etc.	If the contact opens the unit sends a complete closing cycle command (from any position) From this moment until the signal is closed the door stays closed and no external peripheral is detected (including the multi-logics selector). As soon the signal closes the door opens and

			allows again the standard operating.The signal must be short circuited with COM if no device is connected
START 1	NO	Opening contact door opening devices can be connected.	Closing this signal gives the command to open the door. This signal is only monitored in 2 Radars logic, selectable through base or advanced selectors (optionals).
START 2	NO	Opening contact door opening devices can be connected.	Closing this signal gives the command to open the door. This signal is monitored both in 2 Radars logic both in 1 Radar logic selectable through base or advanced selectors (optionals).
SAFE OPEN	NC	Opening safety contact for safety sensors monitoring opening cycle.	If the door is opening and the contact opens, the control board gives a stop command immediately. Opening will only continue after this signal is deactivated. The signal must be connected with COM if no device is connected.
SAFE CLOSE	NC	Closing safety contact for safety sensors monitoring closing cycle	If the door is closing and the contact opens, the control board commands the door to reverse immediately. Closing will continue only after the contact returns closed again. The signal must be connected with COM if no device is connected.
COM		Common electrical contacts.	
AUX IN 1 AUX IN 2	NO	Auxiliary input signal that can be set as follows:	
		0 - DDA opening	Command DDA opening (disabled people).Opens with motor and closes with spring (LOW ENERGY mode) with minimal idle time of 5 seconds
		1 - Emergency open	It opens not depending on the existing logic, over taking as priority also input KEY. It opens door with priority on all other contacts.
		2 - Inter lock with priority	Opens with priority in case of simultaneous command
		3- Inter lock without priority	It doesn't open in case of simultaneous command
		4- Feedback Lock released	Micro switch or contact detecting the status of lock released
		5- Command lock release	This contact allows to unlock manually the lock without opening door through motor.
		6- Single command in double system	In case of Double system, opens only MASTER door.
7- Stand-by	When the contact is closed the door goes in stand by status (unlocked and deactivated) - this logics works with door		

			in closing.
		8-Reactivation after stand-by	When the contact is closed the door start working again after a stand by status.
		9-Step/step function	An opening impulse will open the door. Subsequent closing is possible with another impulse.
		10- Fire alarm	Proswing S: when contact is closed all commands are disabled and door closes through spring
		11- Manual function	Proswing S: when contact is closed door goes in manual function and logic switch fig.1B is no more in function
		12- Stop closed	Proswing M: when contact is closed door goes in stop closed function and logic switch fig.1B is no more in function

EXTERNAL PERIPHERALS CONNECTORS/OUTPUT

SIGNAL	DEFAULT*	DESCRIPTION	
AUX OUT 1 AUX OUT 2	NO	Auxiliary output contact that can be set as follows:	
		0 - Monitoring sensors	It monitors safety sensors.
		1 - Inter lock	To be connected to the input interlock of the other automatism, to obtain interlock logic.
		2 - Door opened	It signals door in opened position.
		3 - Door closed	It signals door in closed position.
		4 - Fault	It signals door in fault.
		5- Repeat lock command	it repeats the command of the electric lock.

* NO =Normally Open NC =Normally Closed

All the input have to be referred to (COM)

NO / NC can be changed see "Setting parameters - display"

 **ATTENTION:** to connect aux out contacts see electrical wiring as shown in Fig 22, Fig. 23 and Fig. 26. Max contact rating: 24V - 100mA

 **ATTENTION:** Absorbing more than the max rating can damage control board.

SENSORS INSTALLATION

The automatism can work with:

- Safety sensors (see Fig.39 A e B): they are fixed on the door and detect the area in front of them in order to avoid contact with persons/obstacles
- Detection sensors (see Fig.39 C e D): generally fixed on the wall or wall frame, detect the approach of peoples and give the input to open the door.

Sensors wiring and control board setting:

ID	SENSOR	WIRING DIAGRAM
17=0 30=1	Safety monitoring sensor in closing (ref. Fig.39 A)	ref. Fig.22
17=0 30=1	Safety monitoring sensor in opening (ref. 39 B)	ref. Fig.23
	Detection sensor (radar) entry (ref. Fig.39 D)	ref. Fig.24
	Detection sensor (radar) exit (ref. Fig.39 C)	ref. Fig.25

If monitored sensors configuration has not been memorized, on display appears E6 error. Exit from this status through procedure LS, see paragraph “parameters adjustment – display”. During this procedure control board checks which sensors are connected and checks if they are correctly working.

 **ATTENTION** during LS procedure stay away from sensors and be sure they are not detecting obstacles. In case they are not correctly wired or working, LS blinks. Abort procedure pushing ESC. Checks sensors and launch LS again.

At the end of LS procedure display shows one of the following configurations:

ID	CONFIGURATION	DESCRIPTION
S0	No monitored sensor detected	There are no monitored sensors wired or the sensors connected will be managed as a normal sensors without monitoring.
S1	monitored sensor only in opening.	There is only monitored sensor in opening. In closing there is no sensor connected or the sensor connected will be managed as a normal sensor without monitoring.
S2	monitored sensor only in closing.	There is only monitored sensor in closing. In opening, there is no sensor connected or the sensor connected will be managed as a normal sensors without monitoring.
S3	monitored sensor in opening and closing.	There are monitored sensors wired both in closing and opening.

The indication remains on the display until it is pressed one of the following push buttons:

- ENT: to confirm the configuration indicated, making sure that it correspond to the real configuration of the connected sensors;
- ESC: to abort the detected configuration and go back to the error status E6.

 **ATTENTION: never confirm the detected configuration if does not correspond to the real configuration of the connected sensors. This might create danger situations or malfunction of the automatism.**

LS procedure can be repeated in any occasion through the parameter LS (look at paragraph “parameters adjustment – display”).

 **ATTENTION: LS must be repeated whenever the configurations of the sensors connected or the automatism are modified.**

⚠ ATTENTION: in case of double Proswing (2 wings) it is necessary to carry out LS procedure on both control boards (master and slave).

Every time after power ON: initially is showed control board firmware version and later, for two seconds, sensors configuration: S0 or S1 or S2 or S3.

In case sensor monitoring fails, the value of the relevant sensor blinks on the display (S1: safety in opening; S2: safety in closing; S3: both). Blinking ends when monitoring is working again.

DIP –SWITCHES SETTING

On the control board there is a dip-switch 8 positions to adjust functionality and basic options.

Changing of setting is considered only after automatism RESET.

DIP	PARAMETER	OPTION		DEFAULT
1	Arm selection	OFF	Push arm	OFF
		ON	Pull arm	
2	Mode LOW ENERGY	OFF	Normal	OFF
		ON	Low Energy	
3	PUSH & GO	OFF	Disabled	OFF
		ON	Enable	
4	Key mode	OFF	Bistable	OFF
		ON	Monostable	
5	Automatism type	OFF	Proswing M (motor)	OFF
		ON	Proswing S (spring)	ON
6	Closing mode for PROSWING S in NO manual logic	OFF	Closing by motor	OFF
		ON	Closing by spring	
	Batteries mode for PROSWING M	OFF	Continuous operation	OFF
		ON	Opening	
7	Opening mode after collision during closing by spring for Proswing S	OFF	No opening	OFF
		ON	Opening by motor	
	Batteries installed for PROSWING M	OFF	Battery not installed	OFF
		ON	Battery installed	
8	Not used	OFF		OFF
		ON		

PARAMETERS ADJUSTMENT-DISPLAY

It is possible to adjust several function parameters through two displays and relevant four push buttons - see Fig. 27.

To properly see the display set the jumper according the opening direction of the wing as shown in Fig.27.

Proceed as follows:

1. Select parameter thorough push button [+] and [-]; press [ENT] to enter in the adjustment procedure.
2. In adjustment procedure, parameter value is indicated in flashing mode. Press [+] and [-] to change value, press [ENT] to memorize value and press [ESC] to come back to parameter selection.
3. During procedure is active a timeout; if no push buttons are pressed for 10 seconds, system exit from adjustment mode.
 - Push button [ESC] allows to exit from adjustment mode without modifications.
 - Only for parameters Sd and Lp need to push pushbutton [ENT] for at least 5 seconds.

ID	DESCRIPTION	SETTING	DEFAULT
01	Opening speed	RANGE: 20°/s ÷ 70°/s (step of 5°/s)	60
02	Closing speed	RANGE: 10°/s ÷ 40°/s (step of 5°/s)	20
03	Idle time	RANGE: 0 ÷ 60 seconds 62 = 2 min 63 = 3 min 64 = 4 min	0
04	Idle time in Low Energy	RANGE: 5 ÷ 60 seconds (adjustment step of 1 second)	5
05	Closing speed with spring (PROSWING S)	RANGE: 1 ÷ 9 (1 minimum speed, 9 maximum speed)	5
	Force in closing position (PROSWING M)	RANGE: 0 – 9 (0=no force, 9= max force)	0
06	Anti-crushing	RANGE: 1 ÷ 9 It is applied both for opening and closing (1=more sensitive; 9=less sensitive)	5
07	Acceleration and deceleration	RANGE: 5 ÷ 30 It is applied both for opening and closing	30
08	Approaching angle	RANGE: 10 ÷ 40 [it modifies both parameters (closing 1/2 of the opening)]	20
09	Electric lock power	0=12 VDC 1=24 VDC	0
10	Lock type	0 = Lock not installed For different type of electric locks please refer to paragraph “electric locks setting”	0

11	Opening delay	RANGE: 0 ÷ 9 Timing depends on the type of electric lock: please refer to paragraph "electric locks setting"	2
12	Lock closing force	RANGE: 0(min) ÷ 9(max)	5
13	Single/Master/Slave	0 = Single 1 = Double Master 2 = Double Slave	0
14	Activation of the electric lock or motor closing according to the logic selected	0 = Disabled 1 = One Radar 2 = Two Radars 3 = One Radar and Two Radars	3
15	Auxiliary input configuration 1	0 = DDA opening 1 = Emergency opening 2 = Interlock door with priority 3 = Interlock door without priority 4 = Feedback lock release 5 = Command lock release 6 = Command Single on Double door 7 = Stand-by 8 = Reactivate the door after stand-by 9 = step/step function (1 impulse open, 1 impulse close) 10-Fire alarm 11- Manual 12-Stop closed	0
16	Auxiliary input configuration 2	0 = DDA opening 1 = Emergency opening 2 = Interlock door with priority 3 = Interlock door without priority 4 = Feedback lock release 5 = Command lock release 6 = Command Single on Double door 7 = Stand-by 8 = Reactivate the door after stand-by 9 = step/step function (1 impulse open, 1 impulse close) 10-Fire alarm 11- Manual 12-Stop closed	1
17	Auxiliary output configuration 1	0 = Sensors monitoring 1 = Interlock 2 = Stop open condition 3 = Stop closed condition 4 = Failure 5 = Repetition of lock command	0
18	Auxiliary output configuration 2	0 = Sensors monitoring 1 = Interlock 2 = Stop open condition 3 = Stop closed condition 4 = Failure 5 = Repetition of lock command	1
19	MultiMaster	0 = No managing Multimaster,	0

		1 ÷ 15 Keynote for MultiMaster connections	
20	Opening safety sensor exclusion	Opening safety sensor angle exclusion. RANGE: 0 ÷ 40% of total angle opening	0
21	Phase displacement in opening for double door	RANGE: 0 – 100 displacement in opening unit of 100 ms (0=synchronized)	0
22	Phase displacement in closing for double door	RANGE: 0 - 100 displacement in closing unit of 100 ms (0=synchronized)	0
23	Polarity safe open input	0 = NA (Normally Open) 1 = NC (Normaly Close)	1
24	Polarity safe close input	0 = NA (Normally Open) 1 = NC (Normaly Close)	1
25	Polarity key input	0 = NA (Normally Open) 1 = NC (Normaly Close)	1
26	Polarity Start1 input	0 = NA (Normally Open) 1 = NC (Normaly Close)	0
27	Polarity Start2 input	0 = NA (Normally Open) 1 = NC (Normaly Close)	0
28	Polarity Aux In 1 input	0 = NA (Normally Open) 1 = NC (Normaly Close)	0
29	Polarity Aux In 2 input	0 = NA (Normally Open) 1 = NC (Normaly Close)	0
30	Polarity Aux Out 1 input	0 = NA (Normally Open) 1 = NC (Normaly Close)	0
31	Polarity Aux Out 2 input	0 = NA (Normally Open) 1 = NC (Normaly Close)	0
32	Force level during LP procedure	RANGE: 5 ÷ 60 (0 = force min 9= force max)	5
33	Opening angle reduction	RANGE: 0÷50%	0
34	Installation on lintel or door	0=on lintel 1=door	0
35	DDA speed	0=Low Energy 1= speed according to parameters 1 e 2	0
36	Batteries mode - only Proswing S	0= no batteries 1= continuous operation 2= opening	0
37	START 2 configuration	0 = as described page 13 1 = DDA active only with switch B -fig.1- in logic 1 2 = DDA active on all logics	0
ST	Stop	Door movement stopped after safety sensors activation or anti-crushing	
TS	Test	0= no cyclical 1= cyclical 2= intensive cyclical	
LS	Learning Sensor (procedure for monitored sensors	1-Select LS pushing buttons [+] e [-] 2-Push [ENT] to start the procedure 3- when displays [--] push again[ENT] for 5 seconds to confirm 4- when disappears [--] leave the push button [ENT]. 3-display shows SO or S1 or S2 or S3) according to the	

		detected configuration (look at paragraph "INSTALLATION page 13" 4- push ENT to confirm the detected configuration, making sure that it correspond to the real configuration of the connected sensors, or ESC to reject the detected configuration.	
Sd	Set to default	1-Select Sd pushing buttons [+] e [-] 2-Push [ENT] 3-when displays [--] push again[ENT] for 5 seconds to confirm 4-when disappears [--] leave the push button [ENT].	
Lp	Learning cycle	1- Select Lp pushing buttons [+] e [-] 2-Push [ENT] 3- when displays [--] push again[ENT] for 5 seconds to confirm 4- when disappears [--] leave the push button [ENT]. Lp starts , see Start Up.	

 During parameters setting any movement of motor is allowed.

When parameters setting it is not used, push button [ENT] is an opening command (only with One Radar or Two Radars logics).

START UP

1. Set main power switch (Fig.1 A) on OFF.

 Make sure to have properly adjusted DIP-Switches, in particular 1 and 5. Make sure contacts KEY, SAFE CLOSE e SAFE OPEN are properly connected or, if not used, connected to COM.

2. Give power supply to the automatism switching on 230 V the general switchboard.
3. Set the switch (Fig.1 A) in ON.
4. Verify lighting of the display and if it shows E6 (if necessary set the jumper to light properly the display (look at Fig.27);
5. Select LS with push buttons [+] e [-], push [ENT] when it shows [--] push again [ENT] for 5 seconds to confirm, when disappears [--] release push button [ENT], the procedure of the acquisition of the monitoring sensors will start (refers to paragraph "sensors installation" page 13/14 to finalize the procedure)
6. If present an electric lock, set parameters 10/11/12/14 (look paragraphs "parameters adjustment-display" and/or "electric locks setting").
7. Pushing buttons [+] e [-], select LP and push [ENT], when it shows [--] push again [ENT] for 5 seconds to confirm the commend; when disappears [--] release push button [ENT]. Door opens and it will start a cycle of parameters acquisition.

 **ATTENTION:** While opening of the door, stop the wing in the position fixed as limit in opening, to get the maximum opening angle. Immediately after this operation, the door will close fully and on display CL blinks. When the door reaches the completely closed position, and CL do not blink any more, it will be possible to test the operation of the automatism pushing the button [ENT]: the door opens and closes normally. The opening angle, during

normal operation, will be reduced compared to the limit detected during the acquisition of the limits so to allow the operation even if the mechanic door limit is missing. The percentage of reduction is defined by parameter n.33. At each start (or RESET operation), automatism must reach the position of door fully closed. Later the first cycle will be at reduced speed.

 After power ON firmware version is displayed and later, for two seconds, is displayed safety sensors configuration (S0 or S1 or S2 or S3).

MESSAGE OR ERRORS CODE

Display are also used to show message or error code:

CODE	DESCRIPTION
OP Fixed	Door opened
OP Blinking	Door opening
CL Fixed	Door closed
CL Blinking	Door closing
E1	Door needs self learning procedure (see Paragraph "Start up")
E2	Wrong arm selection [DIP 1 or switch on break board - see Paragraph "type arm selection"), or wrong selection automatism- DIP 5.
E3/E4	Over Current
E6	Error monitored sensors
E8	NO encoder

OPERATING LOGICS

LOGIC	DESCRIPTION
LOW-ENERGY	In all operative procedures (except Stop Close) it is possible a motor opening with a reduced speed (Low Energy speed) and higher idle time (idle time for disabled people) using the opening command for disabled [AUX IN 1set through parameters 15=0 paragraph "Parameter adjustment display". The following closing is by spring.
PUSH & GO	An opening/closing automatic movement is possible slightly pushing door in opening by hand while it is in a closed position. Set DIP 3 = ON.
SAFE CLOSE	If closing safety sensor detects an obstacle whilst the door is closing, it immediately stops and opens door completely. If sensor detects while door is opening door continues opening.
SAFE OPEN	If opening safety sensor detects an obstacle whilst door is opening, it immediately stops door movement. When detection stops, door continues to open and then close. If sensor detects while door is closing door continues closing.
	If door opens toward a wall (in a corridor, for example) it is possible to cancel the final part sensor detection to avoid wall detection. This

		parameter is modifiable through parameter 20 (see paragraph "Parameter adjustment display").
Logic switch, basic selector, advanced selector operating logic	Manual	START 1 and START 2 are not working. Open and close only through push button on selector or low energy or manually pushing the door.
	1 radar	RADAR ONLY EXIT: Only START 2 input is working. A signal coming from a sensor connected to START2 makes opening and closing of the door. If the door is blocked by a lock or by motor (when no lock is selected), the closing position depends on the type of lock or the setting of parameter 14.
	2 radar	RADAR ENTRY AND EXIT (Automatic): Both input START1 e START2 are working. A signal coming from a sensor connected to one of these two inputs makes the opening and closing of the door. The door blocked by lock or motor (when no lock is selected), the closing position depends on the type of lock or the setting of parameter 14.
	Stop close	Automatism sends door in fully closed position. In this logic the inputs START1 and START2 of the electronic control card are not working; if installed, electric locking system locks door. When there is no lock the door will be blocked with the motor (if selected parameter 14).
	Stop open	Automatism sends door in fully open position.
Opening anti-crushing		If door touches an obstacle whilst opening it stops movement for few seconds. After a while door closes completely at low speed. Sensibility is adjustable through parameter 06 (see paragraph "Parameter adjustment display").
Closing anti- crushing		If door touches an obstacle whilst closing it stops, then opens completely at low speed. After closes at slow speed. Sensibility is adjustable through parameter 06 (see paragraph "Parameter adjustment display").

ELECTRIC LOCKS SETTING

ID	DESCRIPTION	SETTING	DEFAULT
09	Lock voltage ⁽¹⁾	0 = 12 VDC 1 = 24 VDC	0
10	Electric lock type ⁽²⁾	0 = Not used 1 = Impulsive with mechanical relock on closing 2 = Maglock (only24Vdc) 3 = Magnetic bolt 4 = Motorized 5 = Impulsive with relock at power off 6 = Magnetic with delayed relock (only24Vdc)	0
11	Opening delay ⁽³⁾	RANGE: 0 ÷ 9 Time depends on the type of electric lock	2
12	Closing force of electric lock ⁽⁴⁾	RANGE: 0(min) ÷ 9(max)	5
14	Activation of the electric lock or motor closing according to the logic selected ⁽⁵⁾	0 = Disabled 1 = One Radar 2 = Two Radars 3 = One Radar and two Radars	3
15	Aux input 1	4 = Lock feedback ⁽⁶⁾ 5 = Command unlocking ⁽⁷⁾	0

16	Aux input 2	4 = Lock feedback ⁽⁶⁾ 5 = Command unlocking ⁽⁷⁾	1
17	Aux output 1	5 = Lock command repeat	0
18	Aux output 2	5 = Lock command repeat	1

⁽¹⁾ It is possible to manage electric locks 12 and 24 VDC (Parameter 09) with maximum power 15W. For maglocks use only 24 VDC

⁽²⁾ Compatibility with the following types of electric locks:

TYPE	PAR.	VALUE	OPERATION
1-ELECTRIC LOCK WITH MECHANICAL RELOCK ON CLOSING	10	1	See diagram Fig.28 – Keeps door closed without power. After impulsive power supply it unlocks and relocks when it closes mechanically. It requires a push back hit to unlock the door.
	11	RANGE: 0÷9 [t=50÷500 ms]	
2-MAGLOCK	10	2	See diagram Fig.29 – Keeps door closed with power. After power off releases the door. It does not require a push back hit. It is powered again when door is near to fully closed position. Use only maglocks 24Vdc
	11	RANGE: 0÷9 [t=200÷2000 ms]	
3-MAGNETIC BOLT	10	3	See diagram Fig.30 – Keeps door closed with power. After power off releases the door. It requires a push back hit. It is powered again when door is fully closed.
	11	RANGE: 0÷9 [t=200÷2000 ms]	
4-MOTORIZED LOCK	10	4	See diagram Fig.31 – Keeps door closed without power. When powered it retracts locking ratchet with electric motor and releases door. It requires a push back hit. It is powered again when door is fully closed.
	11	RANGE: 0÷9 [t=500÷5000 ms]	
5- IMPULSIVE WITH RELOCK AT POWER OFF	10	5	See diagram Fig.32 Keeps door closed without power. After power supply it unlocks and relocks occurs after 10° of opening by power off. It requires a push back hit .
	11	RANGE: 0÷9 [t=100÷1000 ms]	
6- MAGLOCK WITH DELAY RELOCK	10	6	See diagram Fig.33 - Keeps door closed with power. After power off releases the door. It does not require a push back hit. It is powered again when door is in fully closed position.
	11	RANGE: 0÷9 [t=200÷2000 ms]	

⁽³⁾ For some types of electric lock it is possible to modify the duration of the impulse for activation, or the delay of the opening from the command to unlock. The parameter has different meaning and adjustment range settings according the model of electric lock set using parameter 10.

⁽⁴⁾ To ensure the closing of the electric lock is possible to adjust the closing force.

⁽⁵⁾ When locks are not installed motor keeps door closed.

⁽⁶⁾ It is possible to manage a feedback signal of the lock, so that it indicates the unlocking status: after giving the command to unlock, the control board waits for confirmation before starting opening cycle. If this sign does not reach the control board in a maximum determined time, automatism opens the door anyway.

⁽⁷⁾ It is possible to use one of the aux input as command for manual unlocking of the lock that works in parallel to the automatic unlocking command, it can be used to open the door in manual opening.

SELECTORS TERMINAL BOARD

Connect logic selector (Fig.39 F) using shielded cable 4 wires 0,22mm min, without connecting shield. For wiring refers to Fig.34.

For further information on multi-logic selector use, see the instructions for use

EXTERNAL PERIPHERAL POWER CONNECTOR (15 VDC)

Power value range is 15 Vdc \pm 5 %, depending on the resistive load situations connected to these terminals.

Terminal OUT / 15 VDC : POSITIVE (+)

Terminal COM : NEGATIVE (-)



Do not invert power polarity. When the green led is on it indicates normal voltage presence 15V. If off check mains voltage.

WIRING AND USE FOR DOUBLE PROSWING

Double Proswing is an automatism for double door.

It is possible to realize a double door in two ways:

- 1 with two Proswing installed on each door and then connected together ;
- 2 with two Proswing installed on each door and connected together by a extension kit Fig.36 (OPTIONAL).

The two Proswing, through a wiring on the selector terminal board, can exchange information in order to rightly drive the two doors. It is needed to set one control door as a Master and one as a Slave. The Slave acts only on Master command.

For solution 1 proceed as follows:

- 1- remove all components on both automatism (in order : covers, end cap, control boards, motor gears, transformers);
- 2- fix the aluminum base of each single automatism on the relevant door following instructions described at paragraph "aluminum base holes positioning" – depending on the type of arm used;
- 3- connect together selectors terminal board in order to allow communication between the two cards (Fig. 37)
- 4- assemble again all the components taking care of disconnecting the selector switch of slave door (see Fig. 1B)

For solution 2 proceed as follows:

- 1- remove all components on both automatism (in order : covers, end cap, control boards, motor gears, transformers);
 - 2- put the two aluminum base and the central joining base on a plane surface;
 - 3- insert each base under the lug nut of the two joining parts as showed (Fig. 32);
-  **ATTENTION:** Maintain the orientation of the aluminum bases as shown in Fig 32, so that the black end caps are positioned at the ends.
- 4- tighten screws in order to obtain one single piece;
 - 5- fix the piece to the structure or wall following the instruction and positioning dimensions described at the paragraph "aluminum base holes positioning" and paragraph of the arm depending on the type used;
 - 6- connect together selectors terminal board in order to allow communication between the two cards (Fig. 37);
 - 7- assemble again all the components except end caps. As end caps use the two supplied with the extension positioning the one with logic and power switches on the master door and the one with only power switch on slave door.

 **ATTENTION:** for both cases define, before making any connections, the door and the door Slave Master.

Conventionally:

MASTER DOOR: is the first in opening and the last in closing (in case displacement)

SLAVE DOOR: is the second in opening and first in closing (in case displacement).

For both solutions, we must follow the following instructions to configure the electronic boards:

1- To define Master and Slave use parameter 13:

- MASTER (parameter 13 =1);
- SLAVE (parameter 13 =2);

Even in case of door without displacement it is necessary to set Master and Slave .

 **ATTENTION:** use same power line for the two automatism without any fuses or switches between the two boards. Peripherals command (KEY, START 1 e START 2) have to be connected to Master door. SAFE OPEN and SAFE CLOSE command have to be connected separately on each control boards.

2- In case of door with overlapping it is necessary to set displacement movement. Usually in opening a slight displacement is enough, but in closing, where it is important to be sure to close on the right overlapping, an higher delay between the two doors is needed.

If there is no overlapping:

set on MASTER parameter 21 =0 and parameter 22 =0;

If there is overlapping:

set on MASTER parameter 21 and parameter 22 more than 0

3- To set in function automatism follow Start up paragraph procedure, considering that LS procedure has to be carried out on each control board separately and learning parameter LP (point 6 and 7) has to be carried out only on Master door.

 **ATTENTION:** when learning procedure starts it opens first master door. It is necessary to stop the door in the max opening desired point. Immediately after it starts opening the slave door and even for this door it is necessary to stop the door in the max opening desired point. After this operation the doors will both start closing cycle (CL on display blinking). When arrived in closed position CL stops blinking and door is ready to work.

Selector (optional) must be connected only on Master door. Parameters modified through selector will be changed both on master and Slave door.

Closing cycle will start only if both door have reached their own opening position. Re-opening after command or anti crushing (even on only one door) will be on both doors. Electric lock operation it is possible independently for each door.

Push & go: pushing one door will generate opening for both doors. Anti crushing are independent for each door. Anti crushing in closing generates re-opening for both doors. Anti crushing in opening stops only the door touched, the second one will open completely waiting for the other to finish its opening cycle.

 **ATTENTION**

Parameters modified through Millenniumware must be set separately on each control board.

INTER LOCK WIRING AND USE

Proswing control board can work in inter lock with another Proswing board. Inter lock means that it is possible to open/close only one door at a time. To connect two boards proceed as follow (Fig. 35):

- connect “board with priority” AUX IN 1 to “board without priority” AUX OUT 1-A
- connect “board with priority” COM to “board without priority” AUX OUT 1-B
- connect “board with priority” AUX OUT 1-A to “board without priority” AUX IN 1
- connect “board with priority” AUX OUT 1-B to “board without priority” COM.

Use 4x0,22 shielded cable, do not connect shield.

Set priority for opening in case of simultaneous command through parameters 15 and 17:

- set parameter 15 =2 on “board with priority”;
- set parameter 17 =1 on “board with priority”;
- set parameter 15 =3 on “board without priority”;
- set parameter 17 =1 on “board without priority”.

In this way in case of simultaneous command will open Master as a first door.

 **ATTENTION:** In case of inter lock wiring between two double Proswing the wiring has to be made between the two master boards, whereas one of the two will be considered with priority and the other without priority to the interlock functioning.

 **ATTENTION:** Disconnect jumper near AUX OUT-1 both on board with priority and board without priority (Fig. 35).

POWER KIT (OPTIONAL INSIDE AUTOMATISM ONLY FOR PROSWING M)

To install power kit batteries proceed as follows ref. to fig.38:

- 1) Fix the sponge (A) as shown, using as reference the aluminum base profile bottom line;
- 2) Insert the two batteries (C) in the supporting metallic bracket (B) and fix the whole assembling through screw M6x10 (D);
- 3) Connect cables as shown;
- 4) Pass cables through springs (E) , then under the control board until the part of control board where is located the transformer.
- 6) Connect the batteries cables terminal board to control board (H)
- 7) Insert control board for batteries item (I) on control board
- 8) **Proswing M:** Set dip switches nr.6 and 7 according to the functionality required to batteries or **Proswing S** set parameter 36 according to the functionality required to batteries. For Proswing S it is not possible to install batteries inside automatism, it is necessary to install them outside.

LOGIC SWITCH

In addition to base or advanced selectors there is a switch selector.

This switch selector, see fig. 1 B, is directly wired to control board and allows three logics:

- I Manual (Proswing S) or Stop Closed (Proswing M)
- 0 Automatic (Two Radars)
- II Stop Open

If Base or Advanced selector is connected, switch selector is excluded.

CONNECTOR FOR PC – UNIT CONNECTIONS

For PC connection board (optional) is required to connect the PROSWING unit to a Personal Computer. The following is possible with MILLENNIUM WARE software:

- Advanced adjustments of some operating parameters
- Diagnostic and advanced information on status
- Microprocessor programming

DELIVERY MODALITY

Close the automatism cover and tight screws.

Hand the guarantee and test certificate over filled according to the instructions shown in the certificate.

The certificates must be sent to SESAMO in 8 days from the positive test date.

Hand the technical documentations over to the client .

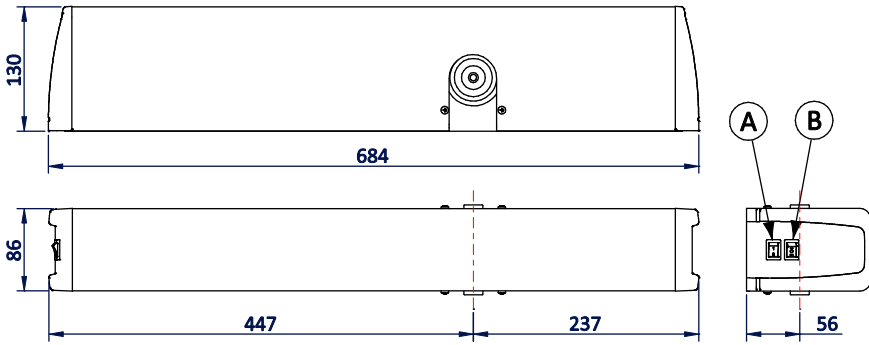

Fig.1

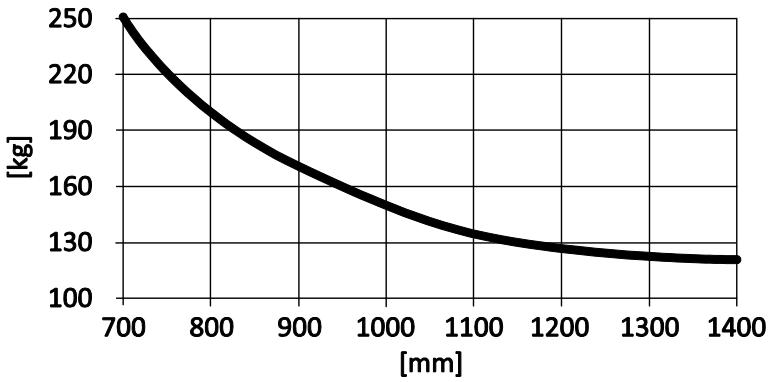

Fig.2

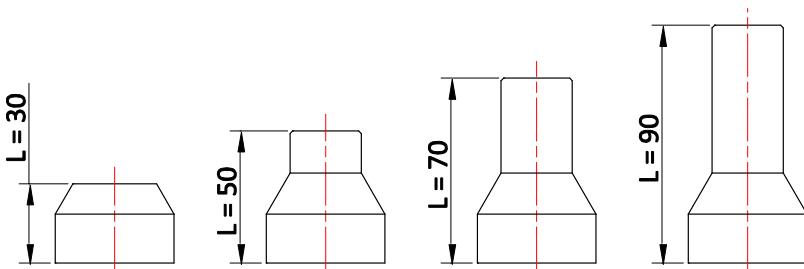
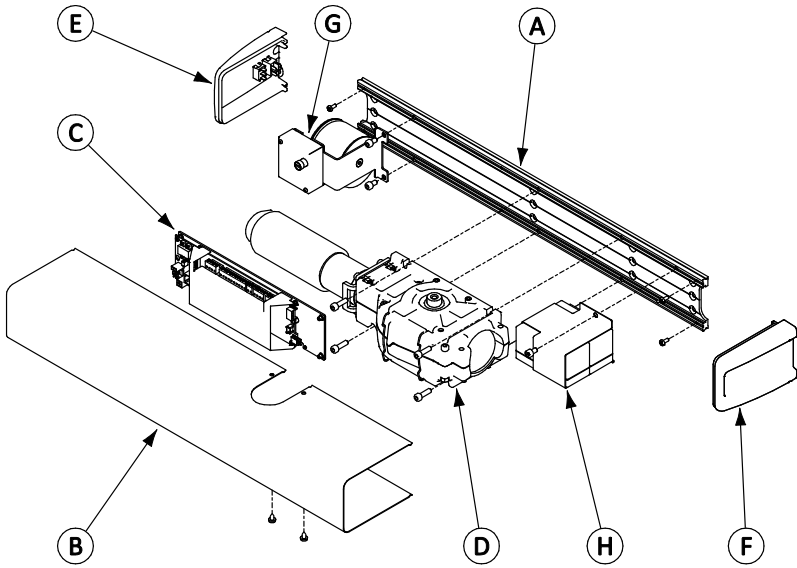
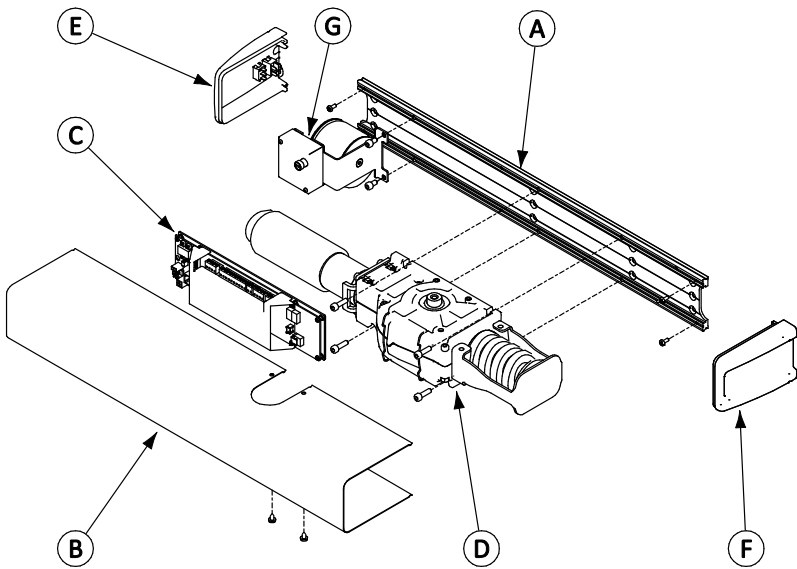

Fig.3



PROSWING M

Fig.4



PROSWING S

Fig.5

SESAMO PROSWING

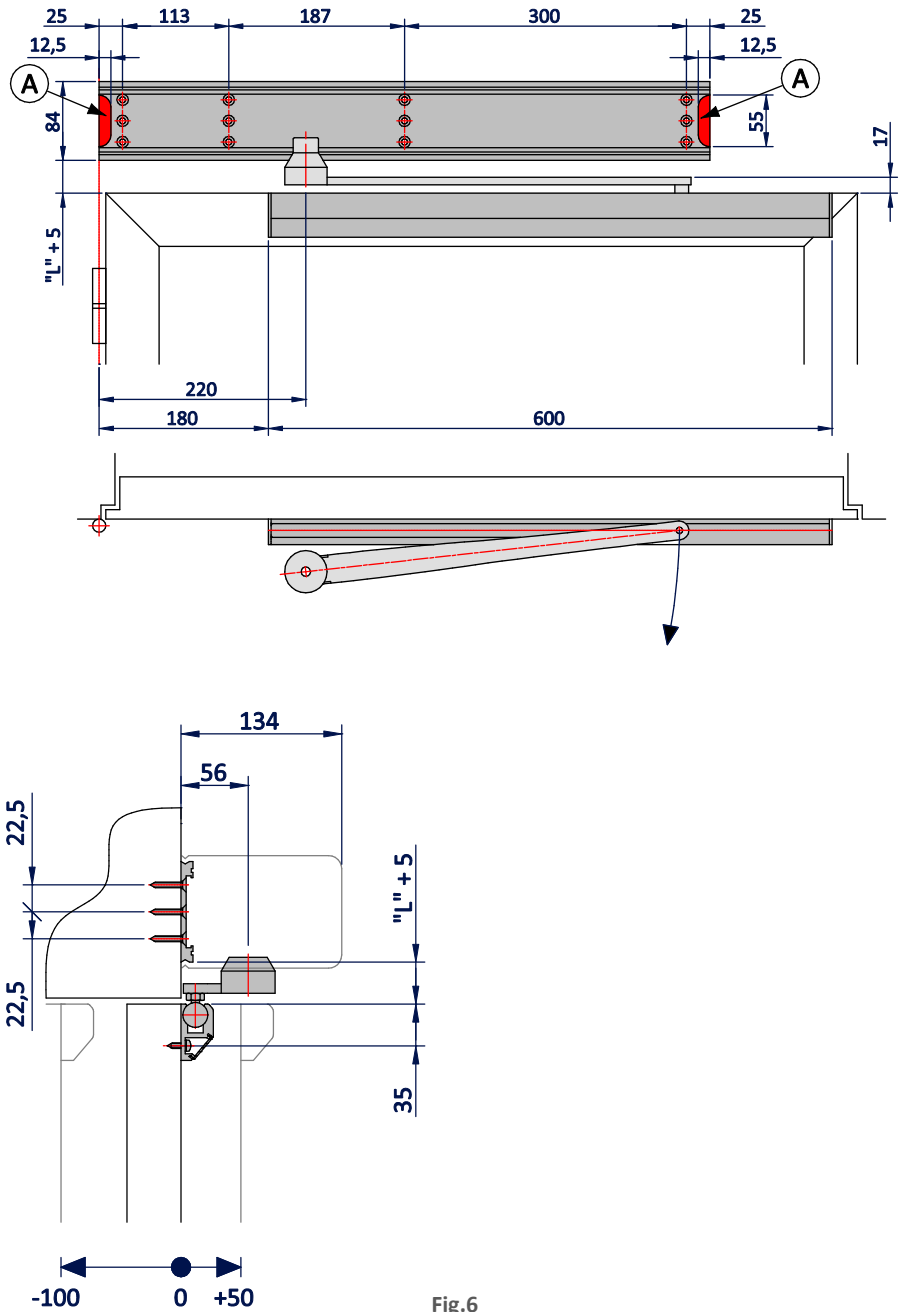

Fig.6

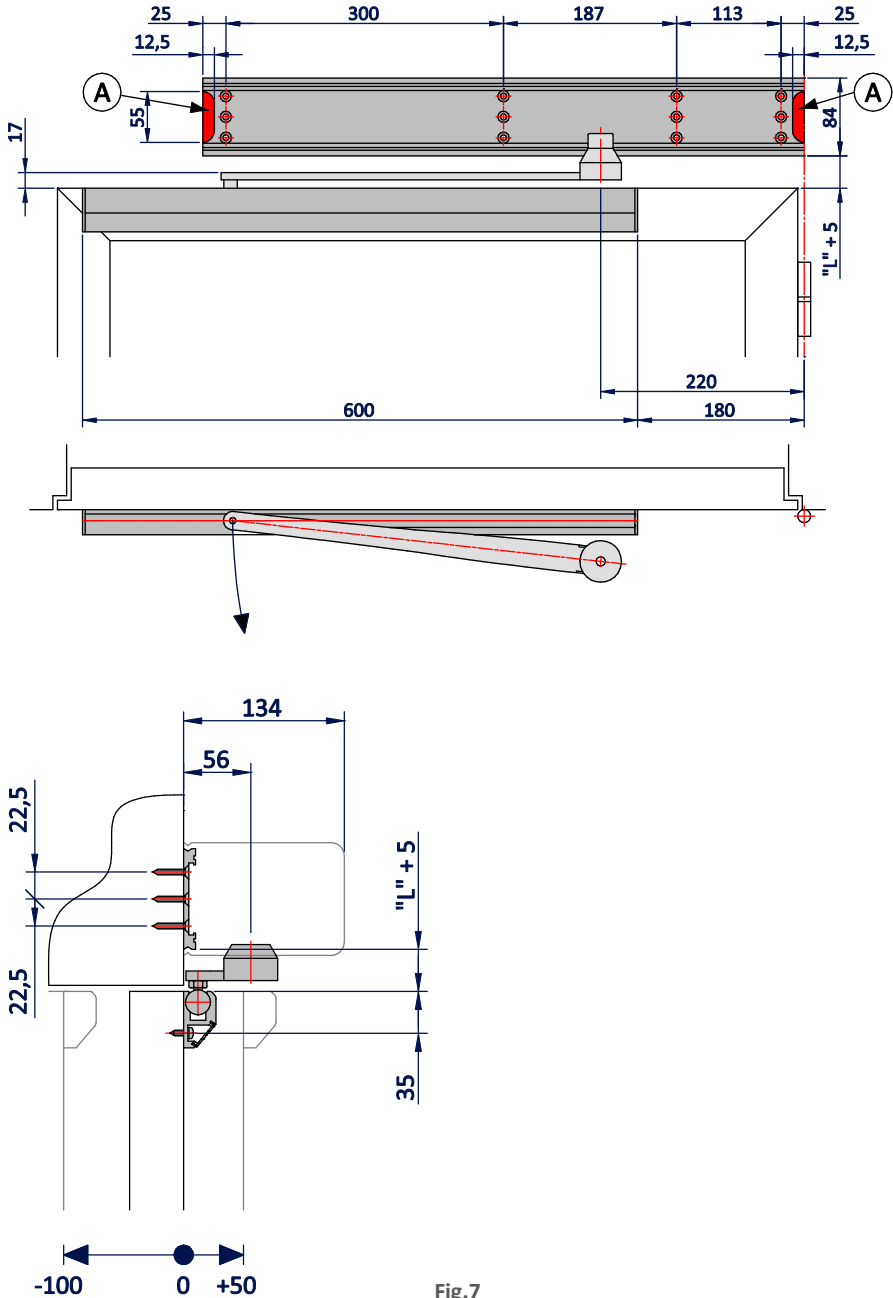

Fig.7

SESAMO PROSWING

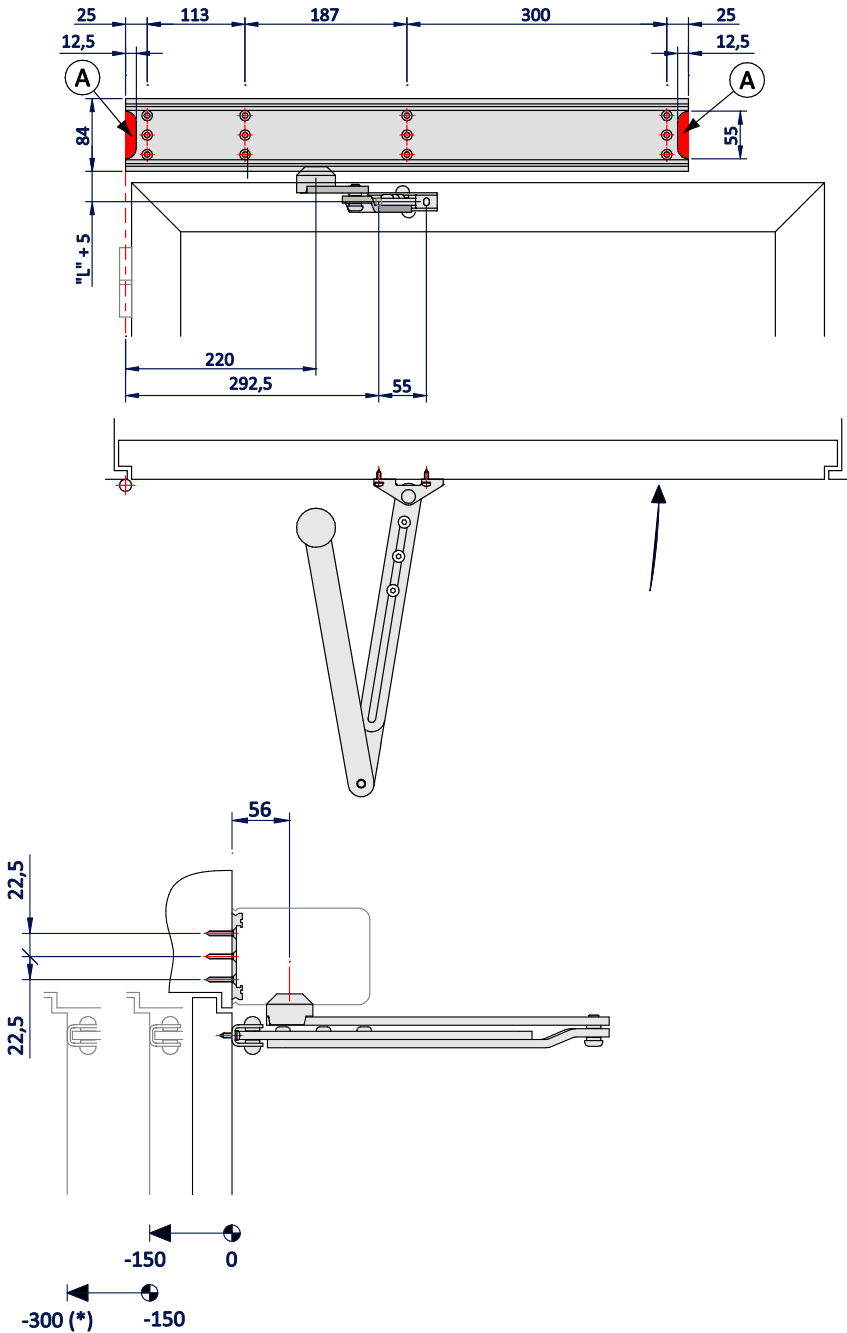

Fig.8

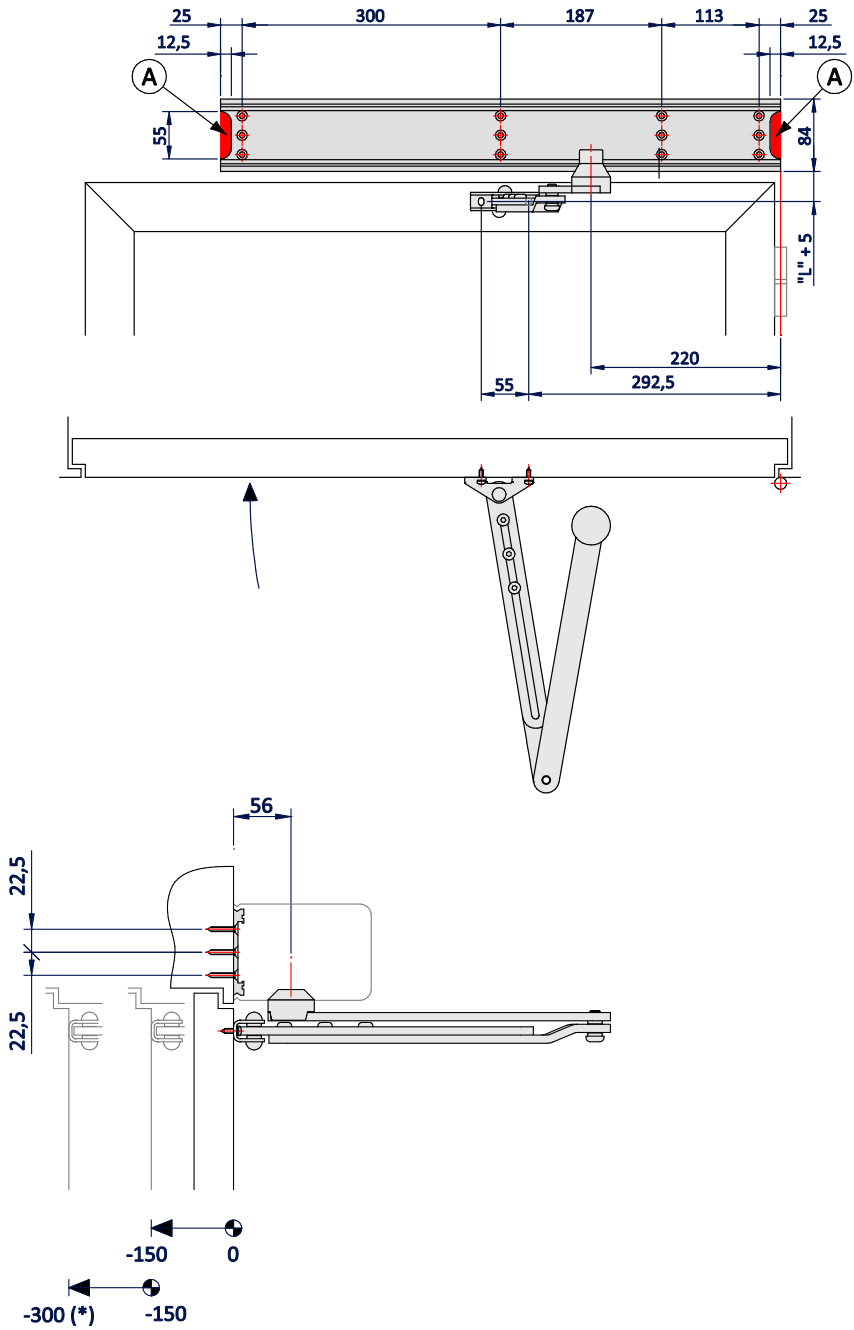

Fig.9

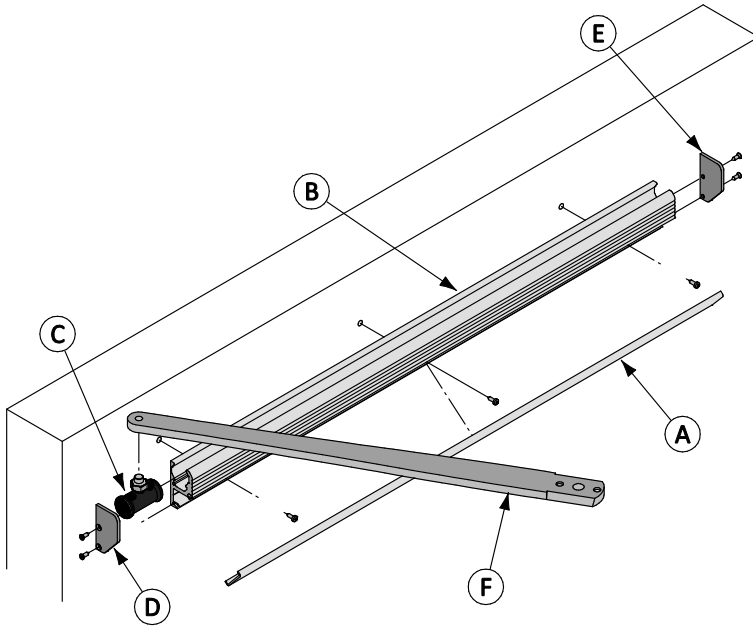

Fig.10

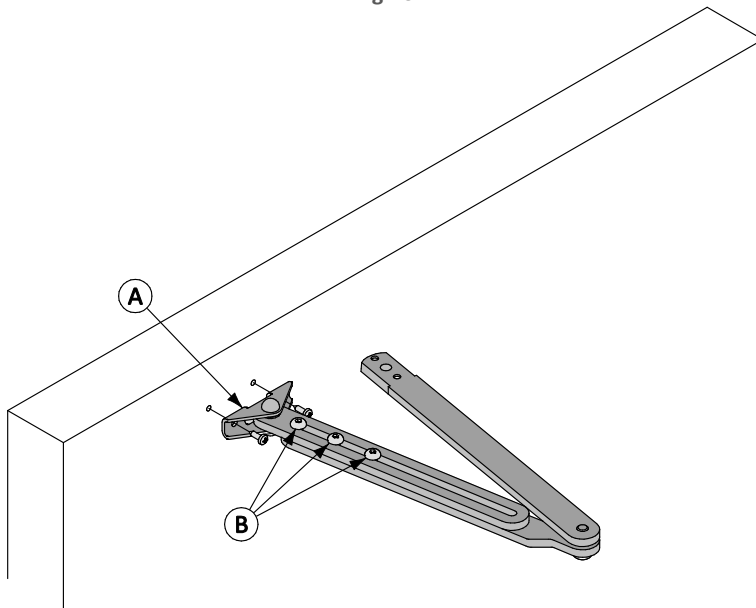

Fig.11

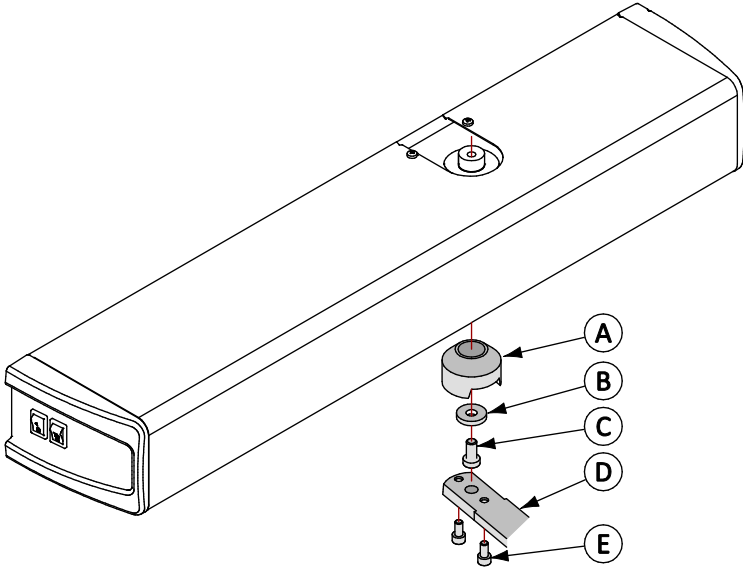
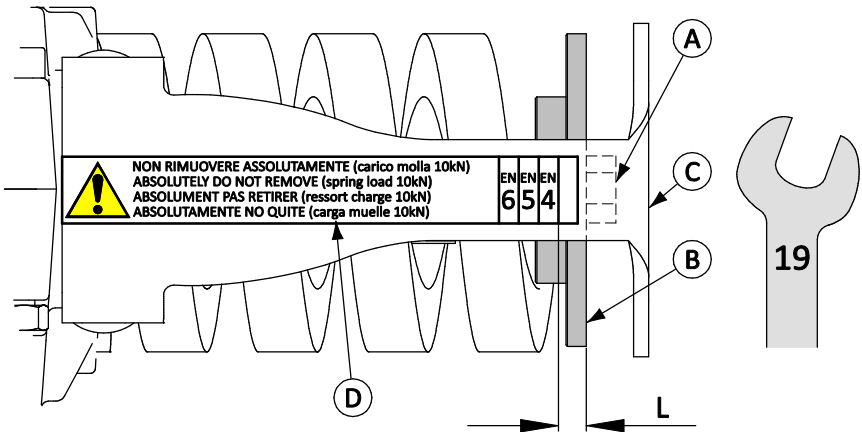

Fig.12



PROSWING S

Fig.13

SESAMO PROSWING

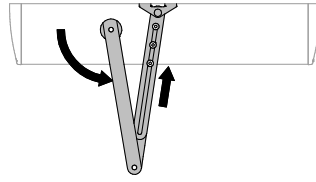
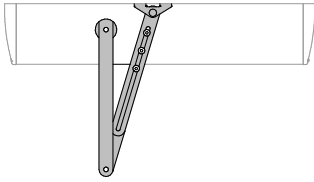

Fig.14

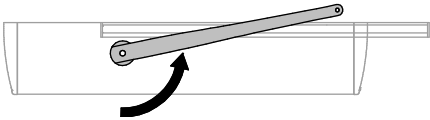
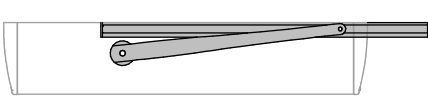
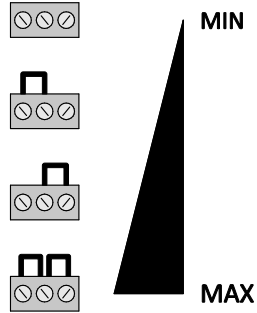
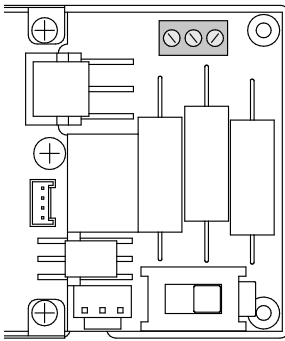
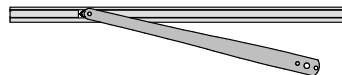
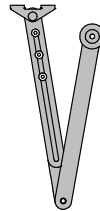
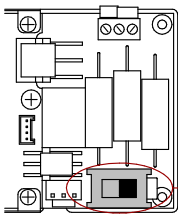

Fig.15



PROSWING S

Fig.16



PROSWING S

Fig.17

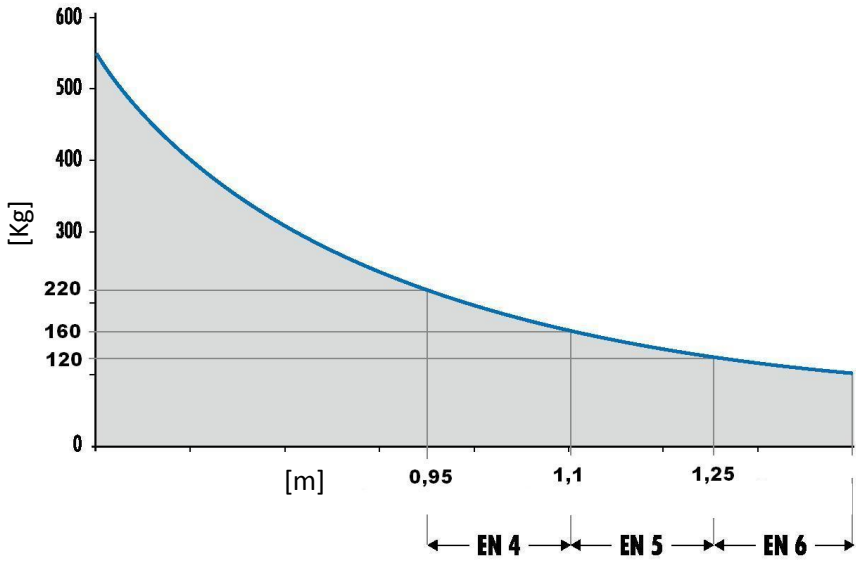

Fig.18

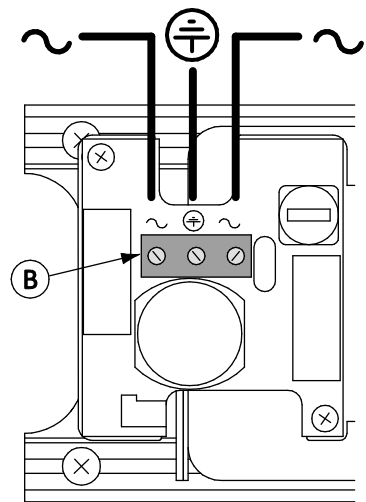
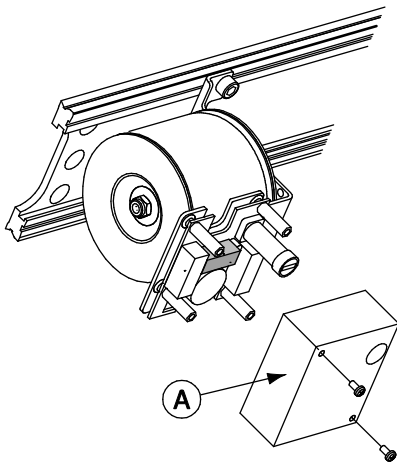

Fig.19

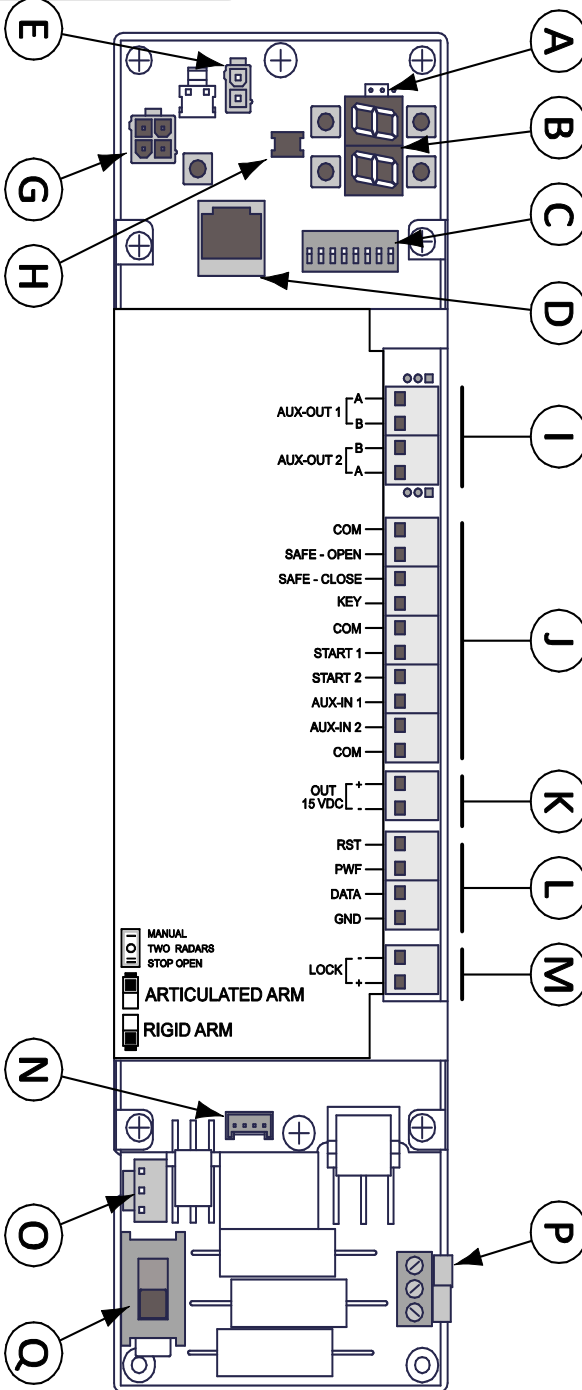

Fig.20
PROSWING S

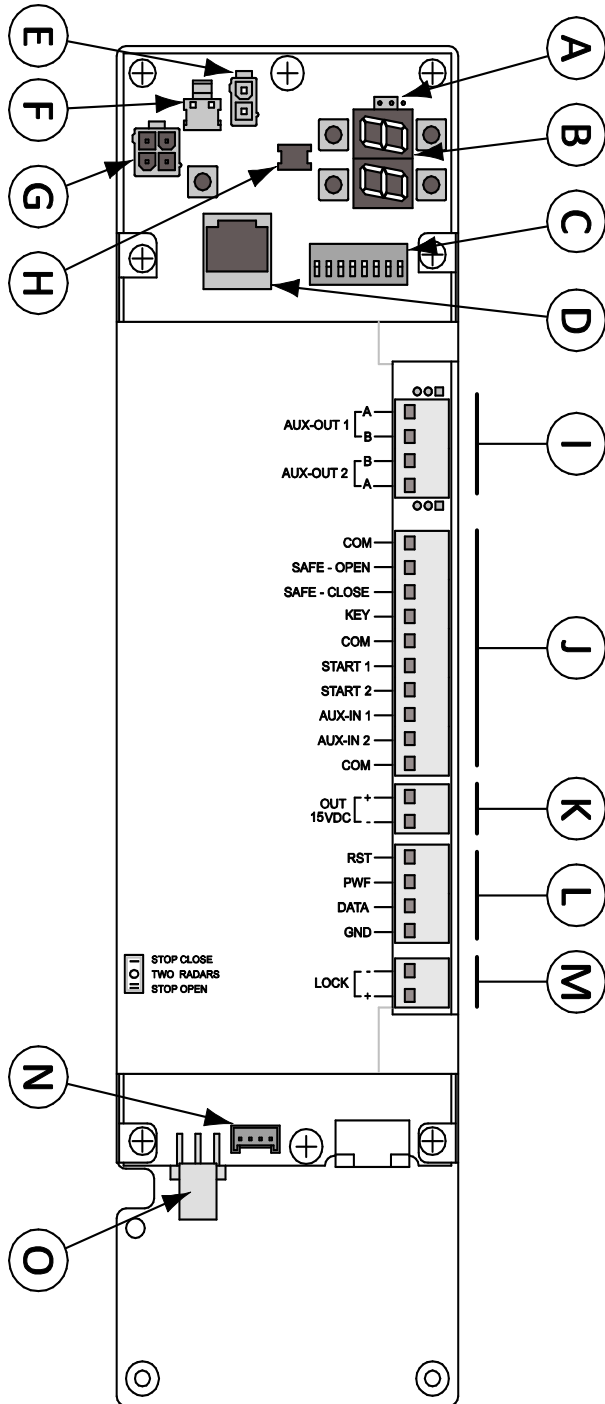

Fig.21
PROSWING M

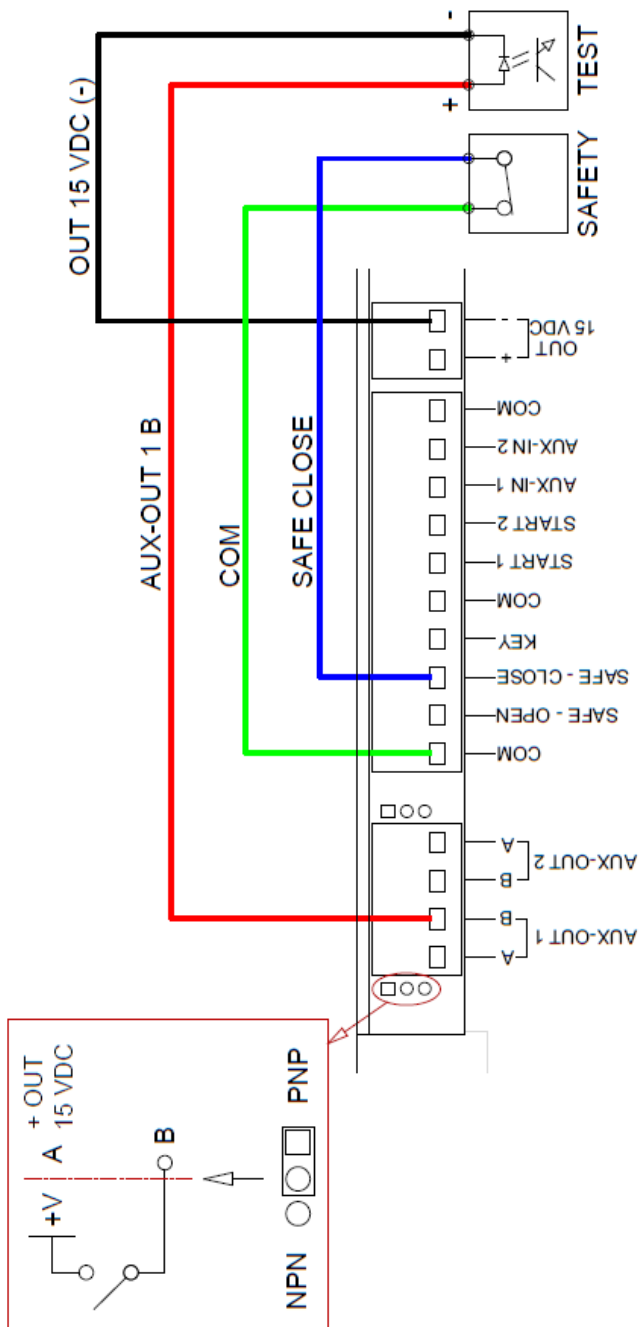

Fig. 22

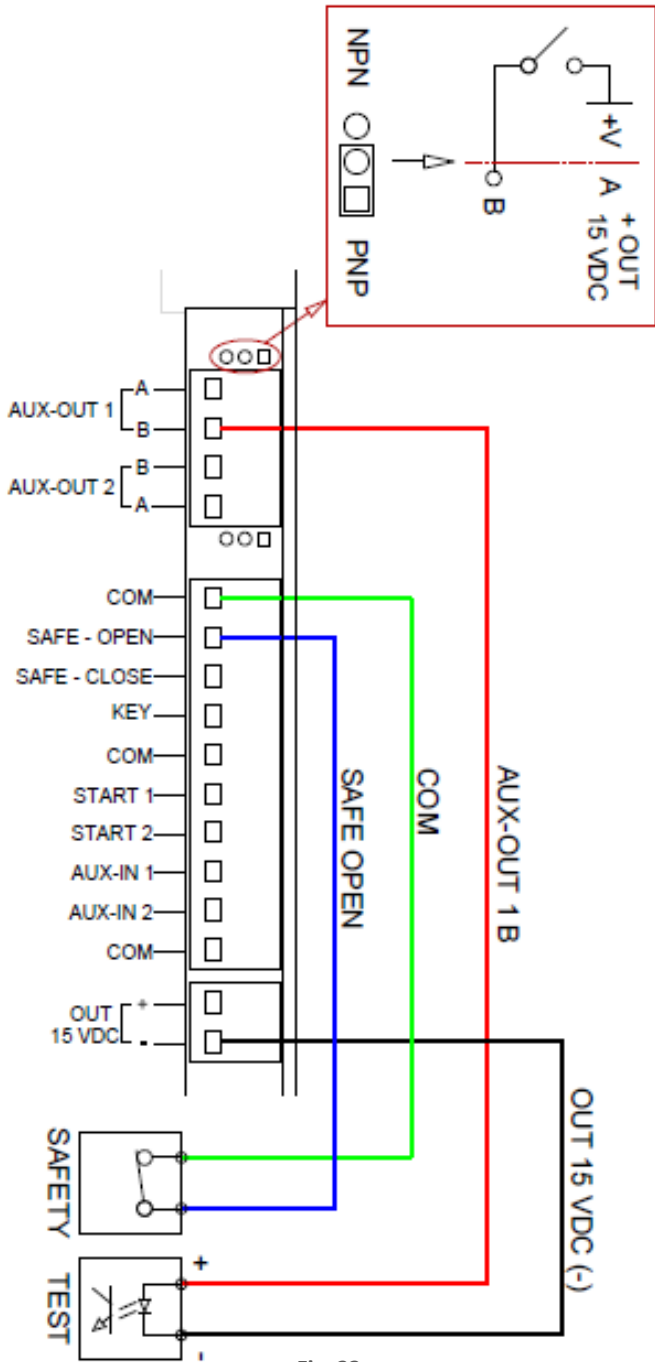

Fig. 23

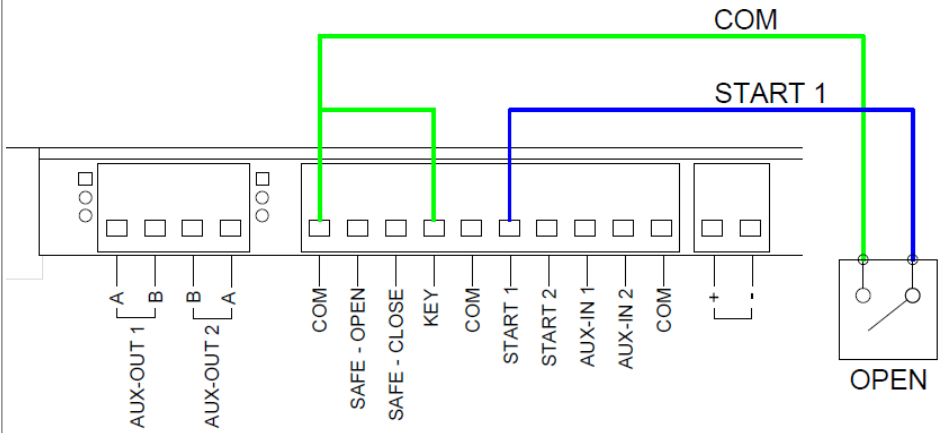

Fig. 24

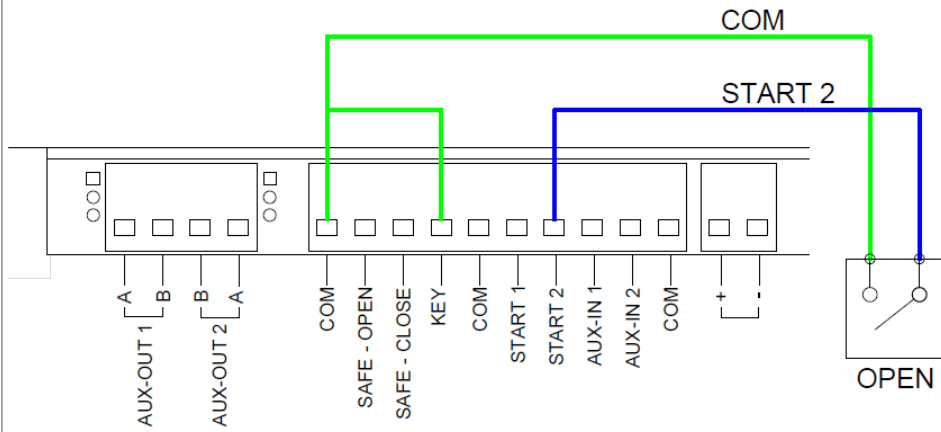

Fig. 25

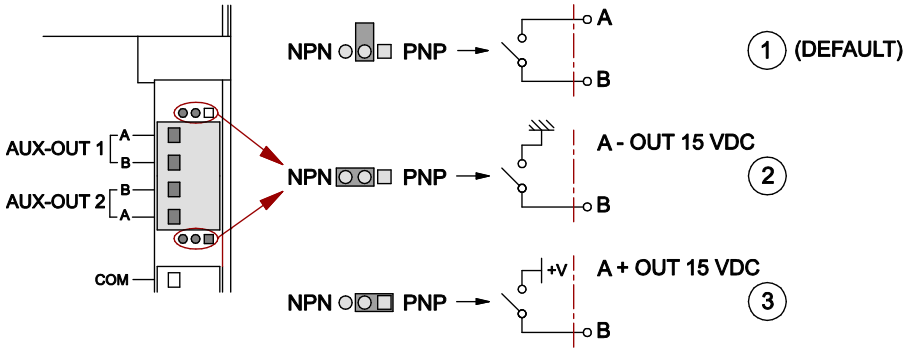

Fig.26

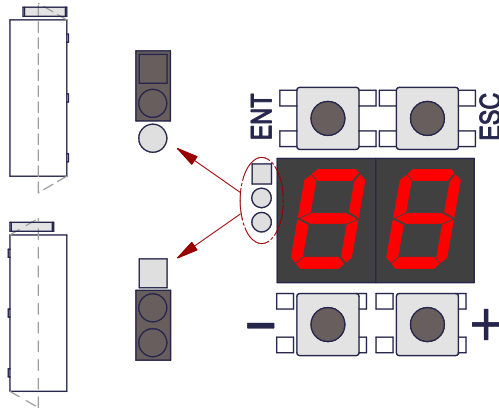

Fig.27

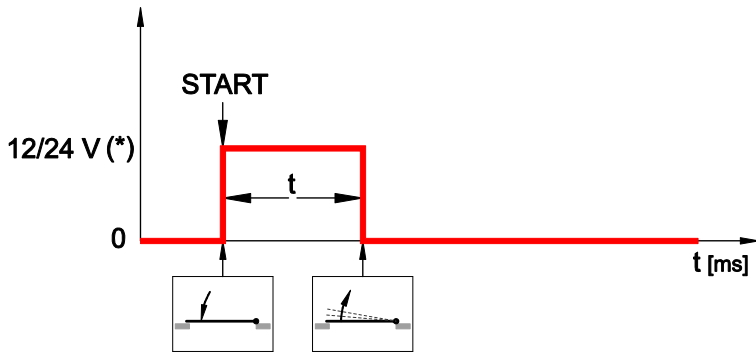

Fig.28

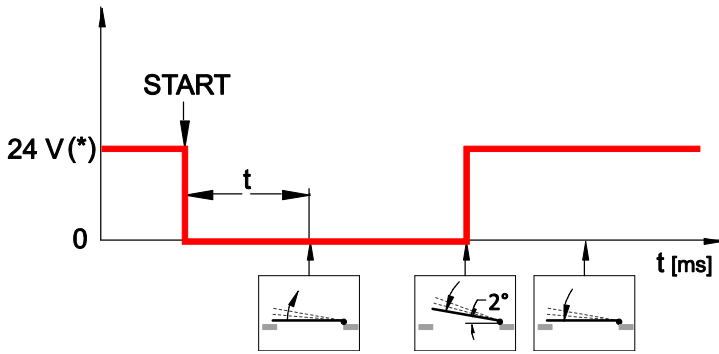

Fig.29

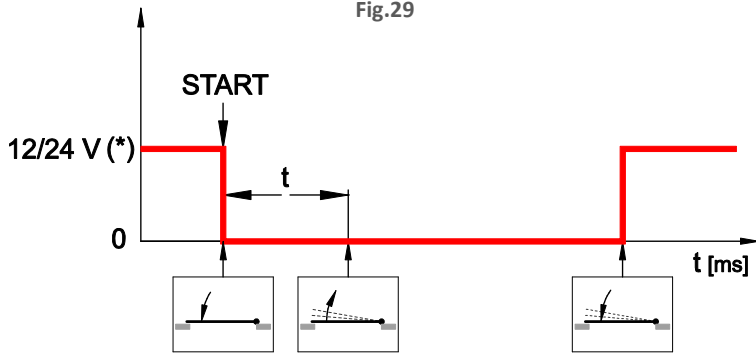

Fig.30

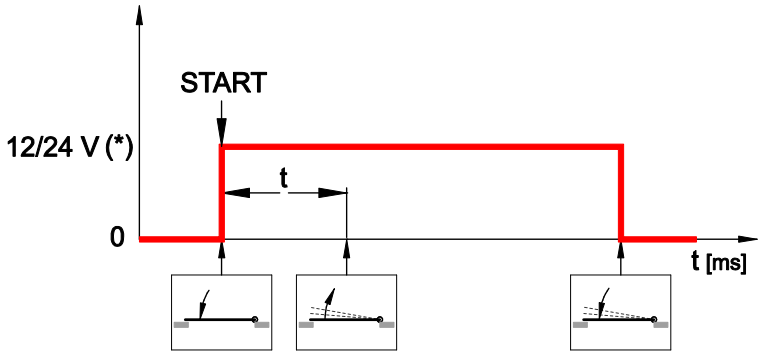

Fig.31

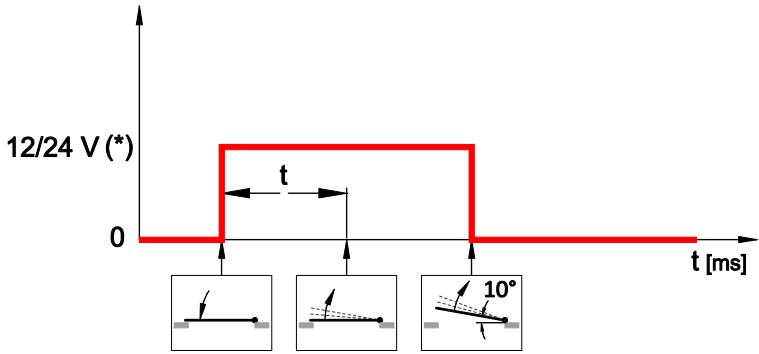

Fig.32

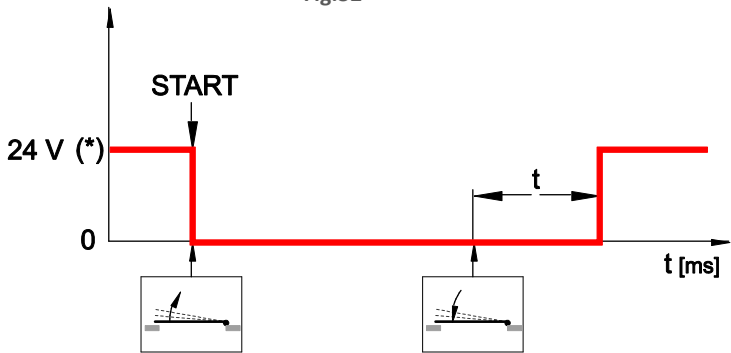

Fig.33

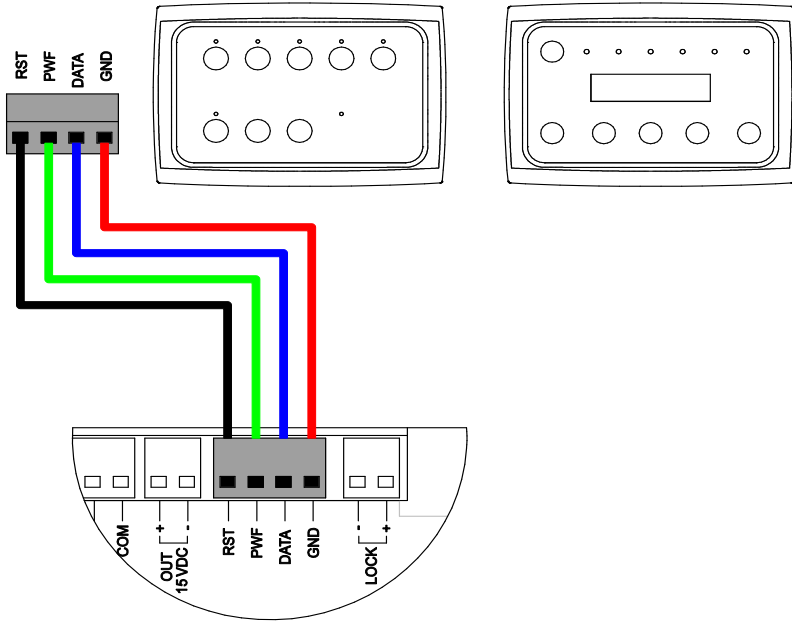

Fig.34

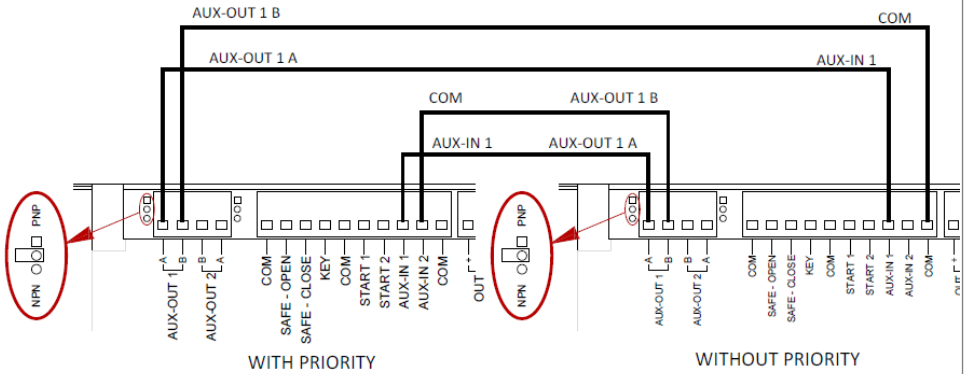

Fig.35

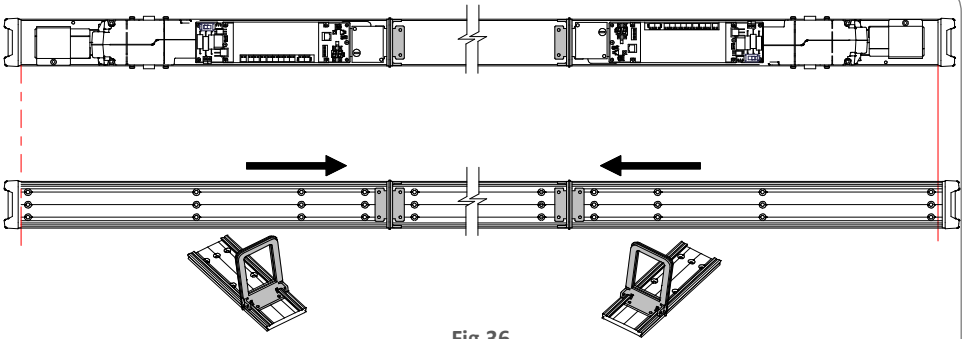

Fig. 36

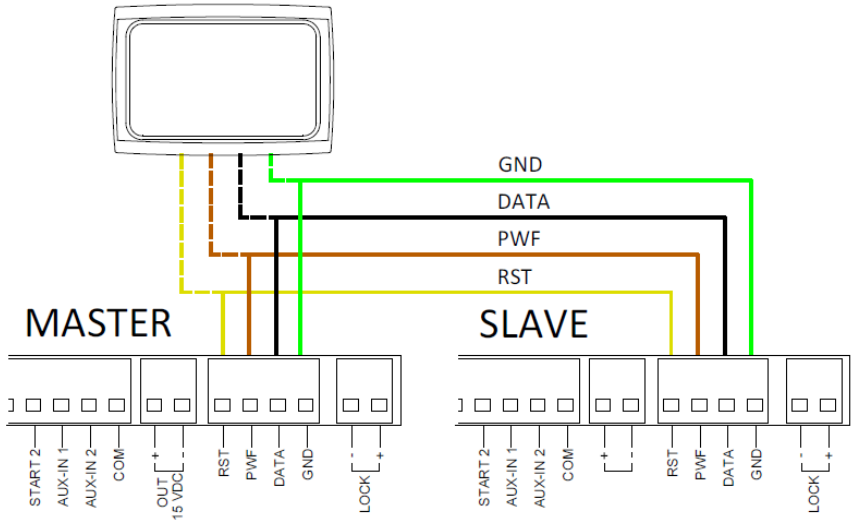

Fig. 37

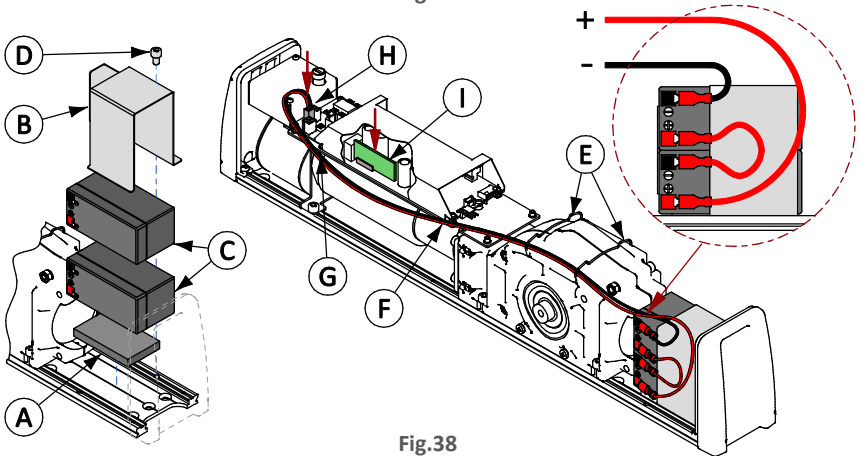

Fig. 38

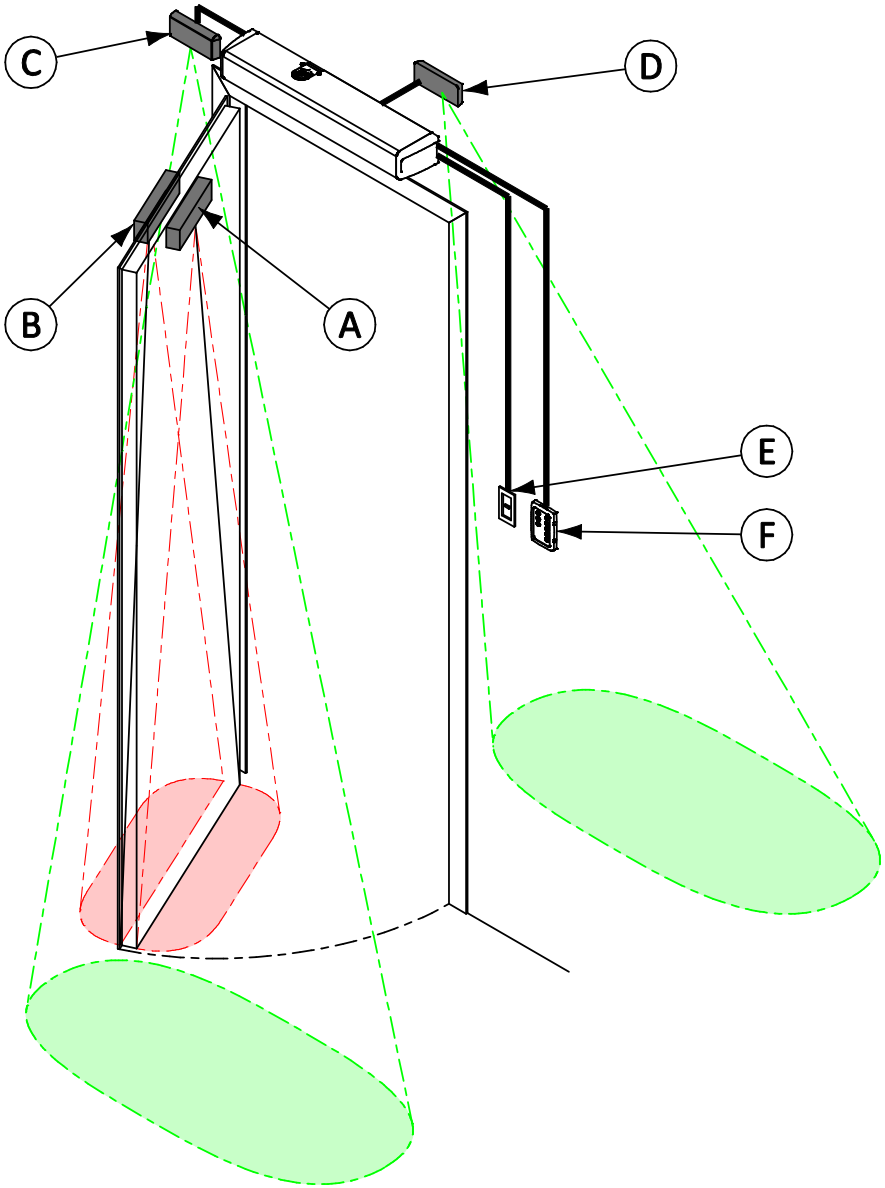

Fig.39

WARNING! This product falls within the scope of the Directive 2012/19 / EU concerning the management of waste for electrical and electronic equipment. (RAEE). The appliance must not be disposed of with domestic waste as it is made of different materials that can be recycled to suitable structures. Inquire through the municipal authority regarding the location of the ecological platforms suitable to receive the product for disposal and the subsequent correct recycling. It should also be remembered that, upon purchase of an equivalent appliance, the distributor is obliged to collect the product for disposal free of charge. The product is not potentially dangerous for human health and the environment, it does not contain harmful substances as per Directive 2011/65 / EU (RoHS), but if abandoned in the environment it negatively impacts on the ecosystem.



The crossed-out bin symbol indicates the compliance of this product with the regulations regarding waste for electrical and electronic equipment. The abandonment in the environment of the equipment or the illegal disposal of the same are punished by law.



MAN_PRO.S.M_EN_10_05_18



SESAMO srl
Str. Gabannone, 8/10
15030 Terruggia (AL) Italy
Tel: +39 0142 403223
Fax: +39 0142 403256
www.sesamo.eu
e-mail: info@sesamo.eu